

SERI/TR-34-089

March 1979

Thermal Energy Storage for Solar Applications: An Overview

Charles Wyman



SERI

Solar Energy Research Institute

A Division of Midwest Research Institute

1617 Cole Boulevard
Golden, Colorado 80401

Operated for the
U.S. Department of Energy
under Contract No. EG-77-C-01-4042

SERI/TR-34-089
UC CATEGORY: UC-62

THERMAL ENERGY STORAGE FOR
SOLAR APPLICATIONS:
AN OVERVIEW

CHARLES WYMAN

MARCH 1979

Solar Energy Research Institute

1536 Cole Boulevard
Golden, Colorado 80401

A Division of Midwest Research Institute

Prepared for the
U.S. Department of Energy
Contract No. EG-77-C-01-4042

PREFACE

This report was prepared as part of Task 3407, Storage Technology Assessment, in the Thermal Conversion Branch of the Solar Energy Research Institute (SERI), a Division of Midwest Research Institute. The report reflects a current assessment of the status of thermal energy storage for solar applications. Comments by Ken Touryan, Frank Kreith, Frank Baylin, and Robert Copeland, all of SERI, were valuable in improving the report. The help of the Department of Energy and its support laboratories in the thermal storage area is also acknowledged in reviewing Section 6.0, DOE Storage Programs.



Frank Kreith
Branch Chief
Thermal Conversion Branch

Approved for:

SOLAR ENERGY RESEARCH INSTITUTE

for 
J. C. Grosskreutz
Assistant Director
Research Division

TABLE OF CONTENTS

	<u>Page</u>
Preface	ii
Abstract	1
1.0 INTRODUCTION	3
1.1 The Role of Storage	3
1.2 Report Objectives and Organization.....	4
2.0 THE ECONOMICS OF SOLAR ENERGY STORAGE	7
2.1 Selected Solar System Studies.....	7
2.1.1 Storage for Solar Home Heating.....	7
2.1.2 Dedicated Storage for Solar Electric Power Plants.....	11
2.1.3 Analyses for Other Applications	22
2.2 The Cost of Stored Energy.....	24
2.2.1 The Effect of Storage Utilization.....	25
2.2.2 The Effect of Storage Efficiency	27
3.0 THERMAL STORAGE METHODS AND MEDIA	29
3.1 Sensible Heat Storage.....	29
3.2 Latent Heat Storage	36
3.3 Reversible Reaction Storage.....	39
3.3.1 Thermochemical Storage Reactions	40
3.3.2 Chemical Heat Pump Reactions	41
3.3.3 Thermochemical Pipeline Reactions	47
4.0 STORAGE VESSELS AND HEAT EXCHANGERS.....	51
4.1 Sensible Heat Systems	51
4.2 Latent Heat Systems	59
4.3 Reversible Reaction Systems	61
5.0 CHEMICAL STORAGE REQUIREMENTS	67
5.1 Equilibrium Considerations	67
5.2 Energy from Storage.....	72
6.0 DOE STORAGE PROGRAMS.....	85

TABLE OF CONTENTS (cont'd)

	<u>Page</u>
7.0 DISCUSSION AND RECOMMENDATIONS	107
7.1 Sensible Heat Storage.....	107
7.2 Latent Heat Storage.....	108
7.3 Reversible Reaction Storage.....	108
7.4 Thermal Energy Storage Applications	110
7.5 Recommendations.....	111
REFERENCES	113

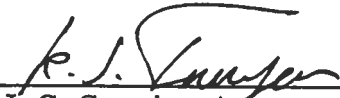
LIST OF TABLES

<u>Table</u>		<u>Page</u>
2-1	Eight Locations Used in Solar Home Heating Study [1]	11
2-2	Relative Electricity Costs in 2015 for an Autonomous Solar Electric Plant as a Function of Collector Field Size and Associated Storage [7]	16
2-3	Relative Electricity Costs in 2015 for a Hybrid Solar Electric Plant as a Function of the Collector Field Size and Associated Storage [7]	20
3-1	Selected Liquid Sensible Heat Storage Media	31
3-2	Thermochemical Storage Reactions	41
3-3	Chemical Heat Pump Storage Reactions	47
3-4	Thermochemical Pipeline Reactions	48

LIST OF FIGURES

		<u>Page</u>
1-1	Possible locations for energy storage in a solar thermal electric power plant	5
2-1	Solar home heating system [1]	8
2-2	Delivered heat cost as a function of storage capacity alone. Units are in energy stored per temperature change of storage media and area of collector [1]	10
2-3	Percentage of an autonomous electric power plant load supplied by solar as a function of the collector mirror area in solar multiples. A minimum collector area of 2.63 solar multiples is required for autonomous operation [7]	13
2-4	Storage capacity for the autonomous electric power plant of Figure 2-3 as a function of the collector mirror area in solar multiples [7]	15
2-5	Percentage of a hybrid electric power plant load supplied by solar as a function of collector mirror area in solar multiples [7]	18
2-6	Storage capacity for the hybrid electric power plants of Figure 2-5 as a function of the collector mirror area in solar multiples [7]	19
2-7	Effect of storage duration on percent energy provided by solar for various collector array areas in Albuquerque [7]	21
2-8	Possible utilization of last element of storage added versus the storage duration to that point	26
3-1	Storage capacity per unit volume as a function of temperature swing for selected liquid sensible heat storage media	30
3-2	Storage media costs in dollars per unit energy stored as a function of temperature swing for selected liquid sensible heat storage media	33

LIST OF FIGURES (cont'd)

	<u>Page</u>
3-3	Storage capacity per unit volume as a function of temperature for selected solid sensible heat storage media 34
3-4	Storage media costs in dollars per unit energy stored as a function of temperature for selected solid sensible heat storage media 35
3-5	Storage capacity per unit volume as a function of temperature for selected latent heat storage materials. The molar composition of mixtures are shown in parenthesis..... 37
3-6	Storage media costs in dollars per unit energy stored as a function of temperature swing for selected latent heat storage materials. The fusion temperature is in parentheses 38
3-7	Chemical heat pump storage for sulfuric acid concentration/dilution with the charging cycle represented by dashed lines (- -) and the discharging cycle by solid lines (-) 42
3-8	Chemical heat pump storage by ammoniated salt pairs for heating applications with the upper diagram for charging storage and the lower for discharging 44
3-9	Equilibrium pressures as a function of temperature for a variety of ammoniated salts [31] 45
3-10	Chemical heat pump storage by ammoniated salt pairs for cooling applications with the upper diagram for charging storage and the lower for discharging 46
3-11	Transmission of thermal energy by the thermochemical pipeline sulfur trioxide reaction 49
4-1	Dual medium thermal storage concept [17] 52
4-2	Observed and calculated thermoelines at various times during storage discharging [17] 54

LIST OF FIGURES (cont'd)

	<u>Page</u>
4-3	Observed and calculated thermoclines at various times during storage charging [17] 55
4-4	Observed and calculated bed temperature profiles at various bed locations during two storage charging and discharging cycles [17] 56
4-5	Prestressed cast iron vessel for pressurized water storage: 1. upper cover; 2. axial tendons; 3. tangential tendons; 4. wedge; 5. liner, and 6. thermal insulation [35] 57
4-6	Salt cavern leaching operation to produce an underground storage cavern [35] 58
4-7	Direct contact system for heat transfer between the latent heat storage medium and an immiscible fluid [36] 60
4-8	Equilibrium pressure-temperature diagram for hydrates of magnesium chloride and water [40] 62
4-9	Cavity converter-heat exchanger for SO_3 decomposition [41] 64
4-10	Details of converter-heat exchanger cavity for SO_3 decomposition [41] 66
5-1	Equilibrium conversion of SO_3 as a function of temperature [23] 70
5-2	Equilibrium pressure for hydroxides as a function of temperature [27] 71
5-3	Thermal energy storage system based on calcium oxide/hydroxide with materials stored at high temperatures. The charging cycle is shown by dashed lines and the discharging cycle is shown by solid lines 74
5-4	Energy released as a function of temperature for calcium oxide/hydroxide with materials stored at high temperatures 74

LIST OF FIGURES (cont'd)

	<u>Page</u>
5-5	Thermal energy storage system based on calcium oxide/hydroxide with materials stored at high temperatures and with waste heat used to evaporate water in a chemical heat pump mode. The charging cycle is shown by dashed lines and the discharging cycle is shown by solid lines. 75
5-6	Energy released as a function of temperature for the chemical heat pump system shown in Figure 5-5 75
5-7	Thermal energy storage system based on calcium oxide/hydroxide with solids stored at 390°C and water condensed, stored, and vaporized using atmospheric temperatures. The charging cycle is shown by dashed lines and the discharging cycle is shown by solid lines..... 77
5-8	Energy released as a function of temperature for the chemical heat pump system shown in Figure 5-7 77
5-9	Energy released as a function of temperature for an ammoniated salts chemical heat pump system with storage of materials at reaction temperatures..... 78
5-10	Thermal energy storage system based on calcium oxide/hydroxide with materials stored at 25°C. The charging cycle is shown by dashed lines and the discharging cycle is shown by solid lines 80
5-11	Energy released as a function of temperature for the calcium oxide/hydroxide system in Figure 5-10 80
5-12	Thermal energy storage system based on calcium oxide/hydroxide in chemical heat pump mode and with materials stored at 25°C. The charging cycle is shown by dashed lines and the discharging cycle is shown by solid lines..... 81
5-13	Energy released as a function of temperature for the chemical heat pump mode of Figure 5-12 81
5-14	Energy released as a function of temperature for ammoniated salts in the chemical heat pump mode with all materials stored at 25°C 82

ABSTRACT

This report presents an overview of current technology and programs including some economic studies in low, intermediate, and high temperature thermal energy storage for solar applications and an assessment of key problem areas. Previous studies of the economic role of storage for solar home heating and stand-alone electric plants are examined first and factors which affect the economics of storage are discussed. Next, the costs and storage capacities of representative sensible and latent heat storage materials are summarized. Various modes of operation are also presented for thermal storage by reversible chemical reactions, but this technology is at such an immature stage of development that its economic and technical potential are not clearly understood. Some new ideas in containers and heat exchangers are reviewed to illustrate possible innovative approaches to reducing storage costs. A more detailed examination is then made of reversible reaction storage, and gas-solid reactions are shown to have desirable attributes for solar energy storage. However, there are problems with heat transfer and heat exchange for these systems that must be solved to make such systems more economically attractive. The DOE programs in thermal energy storage are reviewed in light of this review, and recommendations are made for future program directions which appear at this time to have the greatest potential impact on reducing technical and economic barriers to thermal storage utilization.

SECTION 1.0

INTRODUCTION

1.1 THE ROLE OF STORAGE

Since solar radiation is an inherently time-dependent energy resource, storage of energy is essential if solar is to meet energy needs at night or during periods of cloud cover. Storage provides a reservoir of energy which can adjust for phase differences between local solar energy supply and the load demand. For instance, in home heating the maximum solar energy availability is during the middle of the day while the maximum heating requirements are generally during the night—a difference of about 12 hours. Storage allows an adjustment for this mismatch and solar home heating systems are more economically attractive with storage than without because of the increased effectiveness of equipment utilization [1, 2, 3]. Storage is essential if solar is to meet a large fraction of total energy needs for many such applications.

Energy storage is not a new technology and examples can be found throughout history. For instance, the thick adobe walls used for the homes of the Pueblo Indians in the American Southwest served as a means of thermal storage. The outside walls would absorb energy during the hot days, but the interior would remain cool. Then the stored energy would warm the living quarters during the cold desert nights. Thus, the thermal storage provided by the building mass moderated the interior temperature against the external extremes.

Due to the declining availability of inexpensive fossil fuels, energy storage is again assuming an important role. Most alternate energy sources such as wind, solar radiation, and nuclear power do not naturally provide energy in a pattern which matches the time-dependent character of the load profile and it is necessary to store energy if the particular energy resource is to service the noncoincident portion of the load. The example of the adobe walls provides just this ability to extend periods of energy excess into times of deficiency.

The utility of energy storage is not restricted to solar applications. In fact, improvements in energy storage technology can significantly alter the market in which solar must compete [4]. For instance, electric storage heating units are used in European countries as load leveling devices [5]. A thermal storage unit is charged by electric resistance heaters when a lower off-peak electricity rate is offered. The heat is released from storage at times when the electricity rates are higher. Consequently, the electrical utility demand curve is more uniform and a higher fraction of the load can be met with less expensive electricity produced in nuclear or coal baseload plants rather than by oil-fired peaking plants. Alternatively, the utility can use a central storage unit in a peak shaving operation. A storage device is charged with excess power from a baseload plant during off-peak periods, and the energy is released to the electrical grid during peak demand periods. Again, more baseload plants can be used with a consequent reduction in oil-fired peaking plants and associated high fuel costs. In both applications, less

expensive and more reliable storage lessens the reliance on oil imports, reduces the consumption of scarce fuels, and cuts the price of generated electricity.

Since solar radiation can be converted into various forms of energy, storage is possible by a variety of means. Modern mechanical means include sophisticated flywheels, pumped hydroelectric, and compressed air storage. Thermal energy may be stored as sensible heat changes, latent heat changes, or changes in chemical bond energy. Batteries and other electrochemical processes allow electrical energy to be converted into chemical forms for storage and fuels such as hydrogen may be produced to store energy. Many of these technologies are in their early stages of development, and only a few storage subsystems are presently used in energy conversion systems.

Generally, the choice of the storage media is related to the end use of the energy supply and the process employed to meet that application. For thermal conversion processes, storage as thermal energy itself is most effective. For photovoltaic processes, storage in a chemical form (batteries) appears more appropriate. In the case of some photochemical reactions, the conversion process itself forms the storage media directly. Alternatively, hydrogen can be produced electrically or thermally.

The location and type of energy storage in the overall system is not always as well defined as the above discussion suggests. For example, in a solar thermal electric plant, steam is generated by concentrating solar collectors and is used to run a turbine. The turbine powers a generator to produce electricity. If the system is to withstand transients in insolation or produce power in the evening hours with solar energy, a storage device must be integrated into the process. As shown in Figure 1-1, storage could be provided as thermal energy between the collector and turbine, mechanical energy between the turbine and generator, or chemical energy by a battery (or potential energy in a pumped storage unit) between the generator and the user. Since the turbine and generator are less than 100% efficient, the closer the storage is located to the solar source, the more storage capacity will be required for a given final output of electricity provided all the storage units have the same efficiency. On the other hand, locating storage near the source reduces the size of all subsequent plant components since they are used for longer periods of time. Thus, better conversion efficiencies, lower capital costs, and higher utilization of equipment result. The ultimate type and location of energy storage generally depends on achieving the lowest delivered energy cost with the highest value and satisfactory reliability, and it is necessary to examine the entire system integrated into its specific application to arrive at the optimum solution.

1.2 REPORT OBJECTIVES AND ORGANIZATION

The main objective of this report is to present an overview of economic factors which effect the role of thermal energy storage for solar applications and important storage technologies currently under development. A broad introduction to thermal energy storage is provided. In addition, advanced thermal energy storage by reversible chemical reactions is examined in some detail. Based on the review, problems are identified which warrant further research and development to reduce important technical and economic

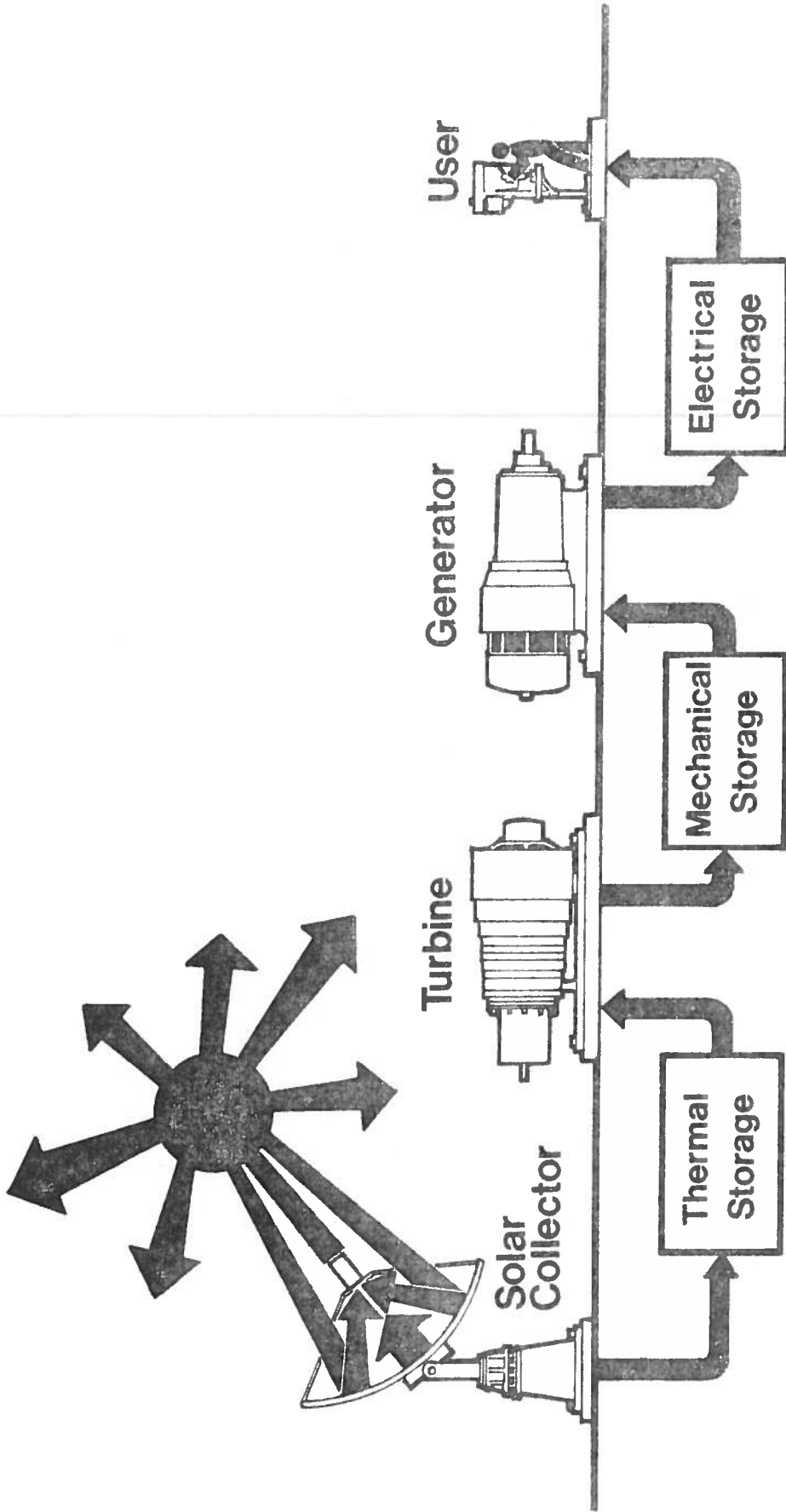

Figure 1-1. POSSIBLE LOCATIONS FOR ENERGY STORAGE IN A SOLAR THERMAL ELECTRIC POWER PLANT

SECTION 2.0

THE ECONOMICS OF SOLAR ENERGY STORAGE

2.1 SELECTED SOLAR SYSTEM STUDIES

The capacity, type, and location of storage which minimize the delivered energy cost for a given solar process depends on the solar availability, the nature of the load, the cost of auxiliary energy, the reliability of the process components, the fraction of energy required from solar, and the price of the system components. These factors must all be weighed carefully for each application to arrive at the particular system design (including storage duration) which minimizes the final delivered energy cost. In the following discussion, summaries of particular cost optimization studies will be presented for thermal storage in home heating and electric power generation. The optimum technical and economic solutions involve particular assumptions about the controlling factors and should not be taken as universally valid. However, these studies illustrate the moderate amount of storage capacity generally thought to be economically attractive for these applications. Results for other important thermal applications such as solar air conditioning and process heat are not included in this report.

2.1.1 Storage for Solar Home Heating

A study of active solar home heating was performed by Løf and Tybout [1, 2]. The following discussion will focus on the storage aspects of their work.

The system studied consists of flat-plate solar collectors tilted from the horizontal with necessary pumps or blowers to transfer heat by water or air from the collectors to storage. All the solar energy provided goes through the storage unit first as shown in Figure 2-1. Since the storage unit is located inside the house, heat losses from storage are to the house itself and do not penalize the solar heating efficiency when indoor heating is desired. They are only true losses when there is no need for indoor heat. Storage may be in a tank of water or rock bin depending on whether water or air respectively is the heat transfer fluid. The stored energy could be used for either space heating or hot water. A full-sized backup heating unit is provided since the authors found it to be very costly per unit of energy delivered to meet the total heating demands by solar energy alone. Both the conventional heat source and the solar heating unit use the same heat distribution system to serve the house heating needs.

A computer program was written to describe the performance of the home heating system. To make the results easily adaptable to different systems, all the design equations were written on the basis of one square foot of collector area. The program requires that the collector temperature exceed the storage temperature by 10°F before fluid is circulated between the storage device and the collectors. This is done to overcome heat losses in the transfer process and to ensure that enough energy is available to justify the electricity cost for operating the pump or blower. Since the

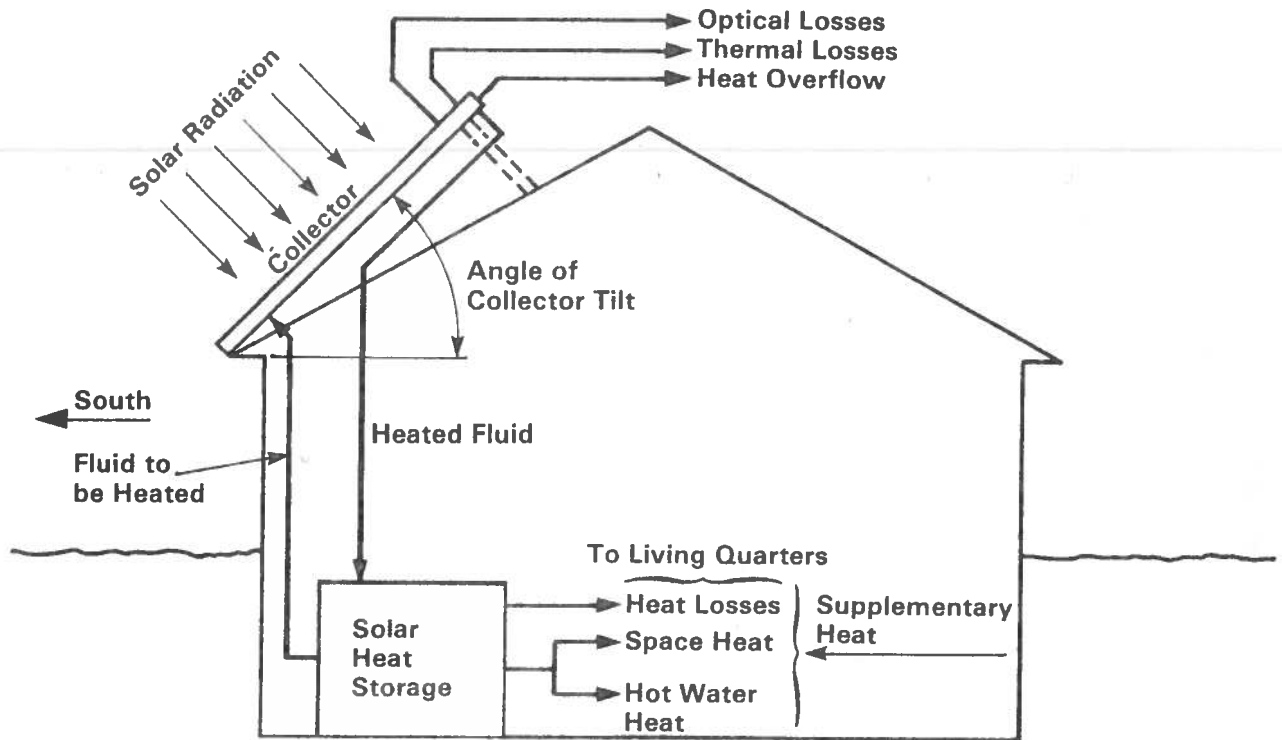

Figure 2-1. SOLAR HOME HEATING SYSTEM [1]

collector temperature must exceed the storage temperature before fluid can be circulated profitably, it is more difficult for the collector to get to a high enough temperature to provide additional energy to a charged storage device than to add heat to a discharged storage unit.

The objective is to find the solar component sizes and the mixture of solar and conventional fuel which minimize the cost of delivered energy. At the time of the referenced study, commercial solar heating systems were not widely used and price information was somewhat sketchy. In addition, the costs employed in the analysis were for 1961-1962 and since they are no longer applicable they will not be discussed in detail here. However, the authors found that changes in price levels did not significantly affect the conclusions of the study and more recent work has substantiated the general storage requirement trends [3, 6]. Therefore, the findings of Løf and Tybout still have merit in matching storage requirements to home heating needs.

The solar heating system performance was determined with the developed model for eight different sites within the United States. The locations shown in Table 2-1 were judged representative of a range of world climates. Cities in parentheses are locations where actual data was taken if the city identified in the analysis is different from the actual monitoring station by a few miles. A full year of hour-by-hour horizontal surface solar radiation, atmospheric temperature, cloud cover, and wind speed data was selected for the year the Weather Bureau advised to be most typical for each location. This information was used in the model.

To keep the number of computer runs reasonable, each of the seven design and demand parameters was varied independently while maintaining all the others constant at levels believed to be nearest their optimum. Each variable was optimized for a 28.5 MJ/°C-day (15,000 Btu/°F-day) and 47.5 MJ/°C-day (25,000 Btu/°F-day) house. The influence of storage capacity on energy cost is shown in Figure 2-2 for three of the cities studied. The percent heating by solar with these designs is shown along the lines drawn. Since only the storage capacity was varied in Figure 2-2, the absolute costs shown on the ordinate do not represent general least cost values. They were judged adequate for the relative comparison made in the study.

One observation from Figure 2-2 is the occurrence of the minimum delivered energy cost for this study at .2 to .3 MJ of storage capacity per °C storage temperature rise and m² collector area (10-15 Btu/°F-ft²) for each of the sites shown with a range of .2 to .4 MJ/°C-m² (10 to 20 Btu/°F-ft²) for all sites studied. This may be translated into storage mass by dividing these values by the heat capacity of the storage material. Thus, storage capacity varies quite closely with collector area. However, Løf and Tybout found that the optimum collector area changes significantly with sites (details are available in References [1, 2]). The somewhat fixed storage capacity to collector area ratio means that the larger collector areas required in colder climates must be accompanied by more storage to meet the higher fluctuation in solar insolation. Overall, the increase in both storage and collector capacities causes the energy delivery cost to be higher for colder cities such as Boston.

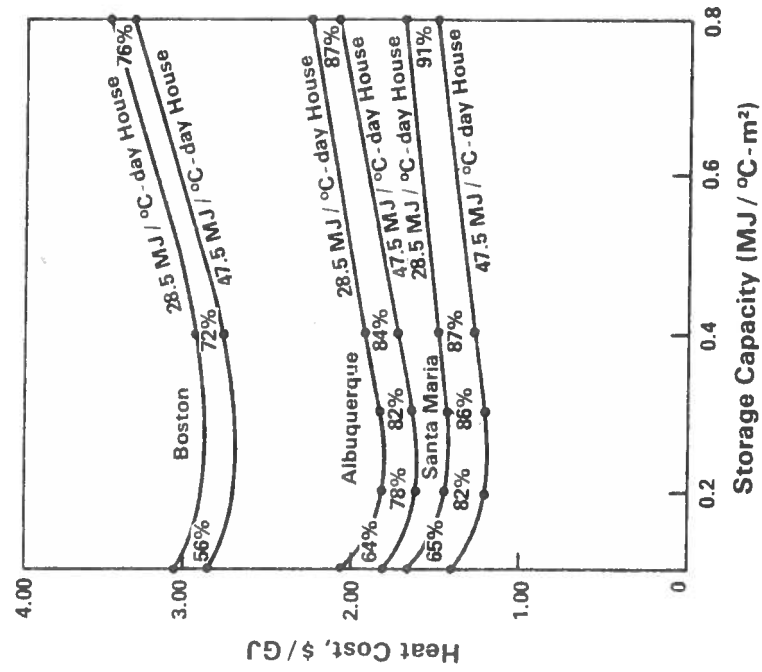

Figure 2-2. DELIVERED HEAT COST AS A FUNCTION OF STORAGE CAPACITY ALONE. UNITS ARE IN ENERGY STORED PER TEMPERATURE CHANGE OF STORAGE MEDIA AND AREA OF COLLECTOR [1]

TABLE 2-1
EIGHT LOCATIONS USED IN SOLAR HOME HEATING STUDY [1]

YEAR	SITE	CLIMATE CLASSIFICATION
1955	Miami	Tropical Savannah
1959	Albuquerque	Tropical and Subtropical Steppe
1956	Phoenix	Tropical and Subtropical Desert
1955	Santa Maria	Mediterranean or Dry Summer Subtropical
1955	Charleston	Humid Subtropical
1960	Seattle-Tacoma	Marine West Coast
1959	Omaha (North Omaha)	Humid Continental, Warm Summer
1958	Boston (Blue Hill)	Humid Continental, Cool Summer

Another important conclusion from this study is the moderate storage capacity required. A minimum storage temperature of 29°C (85°F) is used since heat could not be effectively supplied to the house below this value. A maximum temperature of 93°C (200°F) is specified to prevent boiling of the water. If the storage device could swing through the full 64°C (115°F) temperature range allowed between these limits, only enough heat could be stored at Albuquerque for about one winter day with the selected storage capacity. In Boston, about two days heat could be stored. In practice, even less heat could be stored since a temperature swing of less than 64°C is expected in the winter. In any event, storage durations on the order of one week were definitely not cost-effective in this study for the fixed collector size as shown in Figure 2-2.

2.1.2 Dedicated Storage for Solar Electric Power Plants

The delivered energy cost has also been examined for one type of chemical storage in a high-temperature solar thermal electric power plant. Results obtained by Iannucci [7] augmented by those of Iannucci, Smith, and Swet [8] will be summarized since they illustrate the interaction between storage capacity and the collector field size.

Furthermore, the studies have potential merit for other applications with similar fixed daily demand patterns.

The objective of the studies was to determine the economic role of storage for a stand-alone solar electric plant—a plant which supplies all the electricity needs of an electrically isolated community. The plant is powered either entirely by solar or by solar with a fossil fuel backup. Thermal storage is provided by the $\text{SO}_3/\text{SO}_2/\text{O}_2$ reversible chemical reaction (see Section 3.0 for more information on this reaction). Chemical storage was chosen since the materials can be stored at low temperatures and the long-term storage required for stand-alone plant operation can be provided. When the stored energy must be released, the reaction is able to produce the high temperatures necessary for the electric plant. Chemical storage also provides high energy storage densities. However, for this choice of reaction, compressing the gases for storage could adversely affect the economics.

Storage costs were estimated from the prices of the key components required. Power related costs (reactors, compressors, etc.) were calculated based on the maximum storage charge and discharge rates while energy related costs (chemicals, storage vessels, etc.) were based on the required storage capacity. Although the storage component costs were believed to be reasonable, chemical storage is still in the early stages of development and significant uncertainties exist in the estimates. In addition, less costly or more efficient chemical reaction storage systems could probably be found. Therefore, the results are only an early indication of a possible economic storage role at this point.

A computer model was constructed of the solar plant with chemical storage and fossil backup (if one is specified). The model uses an entire year of hour-by-hour insolation and load data. It determines how the load will be satisfied and how much energy is added to or removed from storage. An hour-by-hour simulation is needed to examine the complex interrelationship between the load, insolation, and storage.

The busbar energy cost (mills/kWh) in the first year of plant operation was minimized. An optimization routine varies the plant component sizes, and consequently the amount of fuel burned, to yield the lowest cost solution. Thus, as the collector field size is changed, the optimization program will determine the proper amount of storage necessary for the hybrid solar/fossil plant to generate electricity at the lowest cost for the consumer. A reasonable spectrum of fuel escalation rates was examined because the cost of fossil fuel affects the optimum solar involvement significantly.

Two different modes of plant operation were considered. In the first, the goal was to maximize the solar output of the plant with economic considerations taken as secondary. The solar output as a percentage of the total energy demand by the load is shown in Figure 2-3 with respect to the mirror area for a nominal 100 MW_e plant in Inyokern, California. The mirror area is specified in solar multiples where a solar multiple of one is the mirror area required to produce 100 MW_e at noon on a cloudless June 21. A solar multiple of at least 2.63 must be provided to meet 100% of the load by solar and this minimum mirror area is called the critical solar multiple (CSM). The value of the CSM

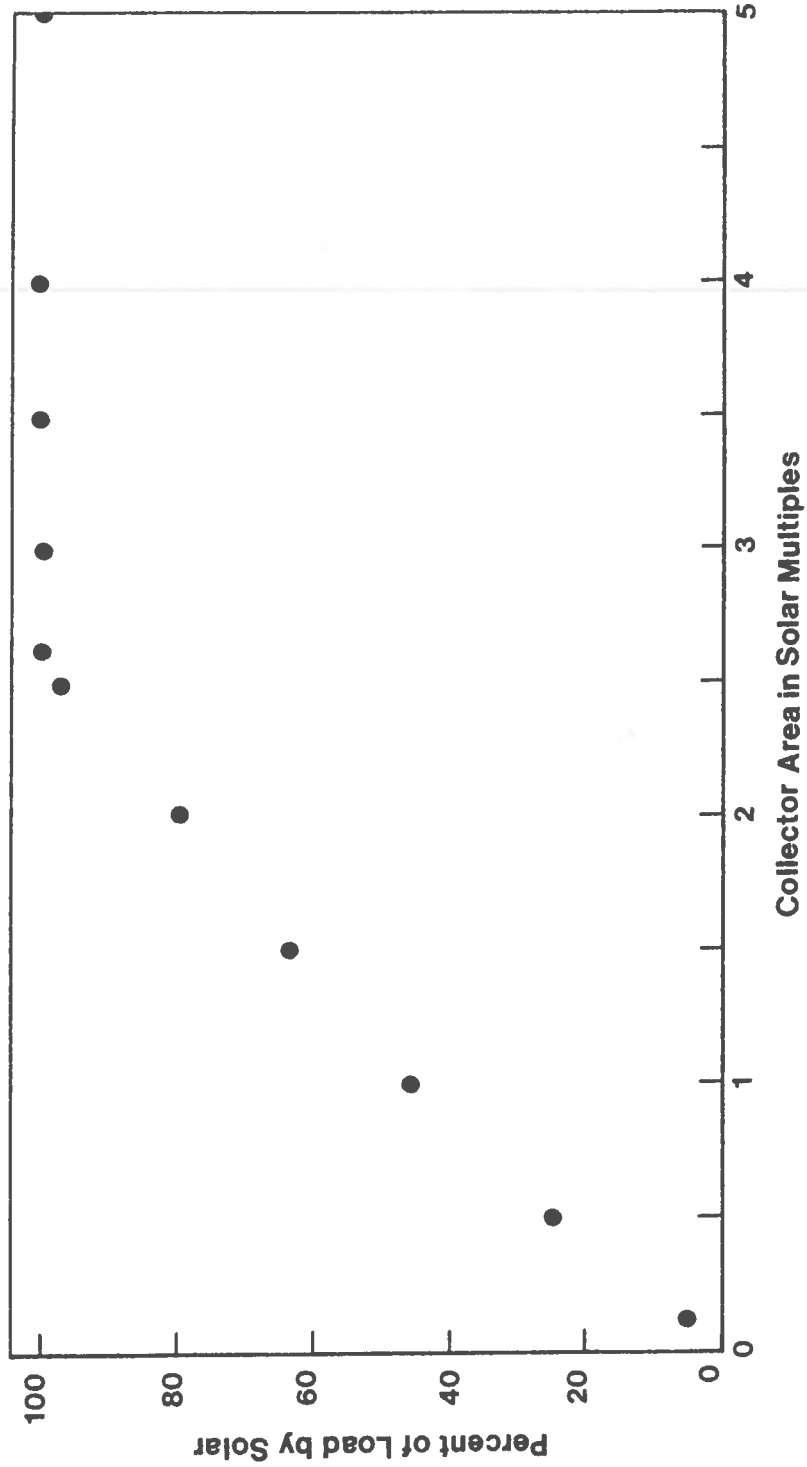

Figure 2-3. PERCENTAGE OF AN AUTONOMOUS ELECTRIC POWER PLANT LOAD SUPPLIED BY SOLAR AS A FUNCTION OF THE COLLECTOR MIRROR AREA IN SOLAR MULTIPLES. A MINIMUM COLLECTOR AREA OF 2.63 SOLAR MULTIPLES IS REQUIRED FOR AUTONOMOUS OPERATION [7]

will change somewhat with storage efficiency. The value of 2.63 corresponds to a storage efficiency of 65%. Figure 2-4 presents the storage capacity in hours of full plant output for the plants of Figure 2-3.

For a mirror field of up to a solar multiple of 2.0, the storage requirements are modest. However, the plant cannot meet the energy requirement by solar alone. The storage requirements rise sharply beyond a solar multiple of 2.0 and peak at the highest storage requirement near the critical solar multiple. For this collector area as well as any additional area, the 100% solar goal is achieved. Further increases in collector area result in a dramatic decrease in storage requirement until the minimum storage requirements for a 100% solar plant are achieved at a solar multiple of 3.0 to 3.5. The minimum storage duration must be adequate to last the longest time span without solar insolation and cannot be reduced with further increases in collector area.

The coupling of chemical storage requirements to collector area has interesting consequences for the busbar energy costs (BBEC) shown in Table 2-2 for the year 2015 assuming a 7.5% fuel escalation rate. Two different collector area costs are shown in this table. Only collector areas greater than the CSM are shown since less collector area cannot provide 100% of the requirement with solar energy. The price rises sharply as the collector field size approaches the critical solar multiple because of the increase in storage capacity requirements. Up to this point, no energy can be discarded at all in an effort to attain the 100% solar goal. However, once a collector field greater than the CSM is available, energy can be discarded and there are many ways to provide 100% of requirement from solar energy. Thus, storage is traded off for more mirrors. It is this freedom to discard energy which allows economic factors to control the 100% solar solution.

Once the minimum possible storage duration to provide 100% solar electricity is attained, further increases in collector area simply add to the field cost without reduction in storage and the BBEC rises linearly. Consequently, the minimum BBEC for this particular chemical storage system occurs at 3.5 solar multiples for a collector cost of $\$60/\text{m}^2$ and 3.0 solar multiples for a cost of $\$120/\text{m}^2$. The fact that the optimized collector area is close to the value for the minimum possible storage duration suggests that storage is relatively expensive. Thus, the collector field will be sized greater than the CSM for the storage system considered unless the field cost is extremely high in which case the plant would probably not be built at all. However, if the storage system cost is reduced, the optimum field size will decrease until the minimum sized field is reached at the CSM for free storage. The cost of energy will drop for a cheaper storage system choice. The interaction of energy storage duration and collector field size are discussed in Reference [9].

While the collector area is the most expensive item at the optimal cost solutions, it is not the minimum possible for 100% solar. Thus, the increase in collector costs beyond the CSM is more than offset by lower storage costs at the lowest BBEC. At the lowest cost solution, decreasing the collector area slightly causes the storage duration to increase quickly, but the added storage capacity adds so little to the electricity cost that the BBEC rises slowly. However, the increased storage duration adds reliability to the

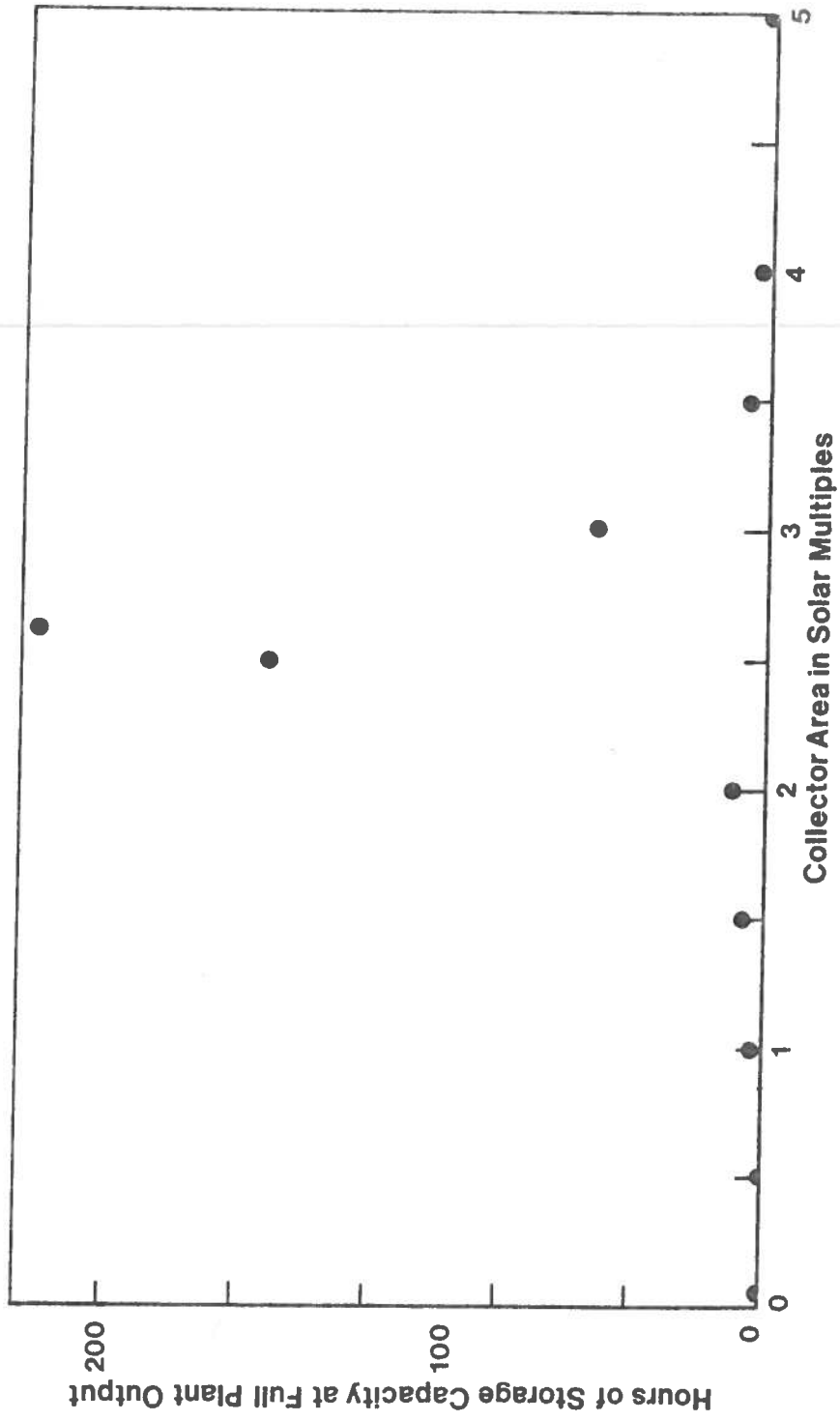

Figure 2-4. STORAGE CAPACITY FOR THE AUTONOMOUS ELECTRIC POWER PLANT OF FIGURE 2-3 AS A FUNCTION OF THE COLLECTOR MIRROR AREA IN SOLAR MULTIPLES [7]

TABLE 2-2
 RELATIVE ELECTRICITY COSTS IN 2015 FOR AN AUTONOMOUS SOLAR ELECTRIC
 PLANT AS FUNCTION OF COLLECTOR FIELD SIZE AND ASSOCIATED STORAGE [7]

Percent Satisfied by Solar	Solar Multiple	Receiver Size (MW_t)	Storage Charge Rate (MW_t)	Storage Capacity (Hours)	$\$60/m^2$ Relative Electricity Cost	$\$120/m^2$ Relative Electricity Cost
100	3.0	596	286	52.8	.74	.97
100	3.5	550	250	36.1	.71	.98
100	4.0	519	233	34.6	.73	1.04
100	5.0	478	221	35.2	.80	1.18

plant in the event of uncharacteristically long periods without sun. Therefore, it may be desirable to design the plant with somewhat less collector area and more storage than the lowest cost solution.

The second mode of power plant operation was to minimize the busbar energy cost without regard to solar involvement. Thus, a fossil fuel backup system was used to supplement the power provided by solar. This operation would likely be more in tune with the strategy a utility would employ under ordinary market conditions. In this case, a collector field with less area than the CSM is allowed.

A fuel escalation rate of 7.5% per year was assumed to assure a solar involvement. Figure 2-5 shows the percent solar energy provided as related to the collector area measured in solar multiples. The result is similar to Figure 2-3, but the percent solar provided is less for any collector area and it asymptotically approaches the 100% solar contribution instead of actually attaining that value. Figure 2-6 shows greatly reduced storage requirements for the hybrid plant relative to the 100% solar plant. The storage capacity still peaks near the CSM but at a value of only 4% of that seen in Figure 2-4.

In this study, the optimum hybrid power plant has a collector area less than the CSM. The storage capacity also tends to be low with values usually under 15 hours. The plant now needs appreciable amounts of energy from a backup source. However, due to the lower collector area and storage needs, lower cost solutions result. For instance, at a solar multiple of 2.5, 90% of the energy is supplied by solar but at a busbar energy cost less than that for a pure solar plant. Table 2-3 presents the relative electricity costs for the optimum hybrid plants with two different collector costs.

Once again, the freedom to discard collected solar energy yields a much more economical solution. If enough storage is provided to accept all of the available solar energy throughout the year, a low utilization of the storage results in consequent high costs. Thus, if a backup is available at reasonable cost, it is less expensive to employ the backup to meet these infrequent demands than to store all the captured energy for the storage system used in this study. Allowing hybridization between solar and fossil energy sources can greatly reduce the storage, and therefore costs, relative to a 100% solar solution.

A change in the pattern of insolation availability (storm duration) does not affect the storage capacity for a hybrid plant as much as one for autonomous operation [8]. Extended periods without solar occur infrequently while occultation occurs every night. Thus, overnight storage requirements exert far more influence on the optimized storage duration than extended outages for a hybrid plant. On the other hand, a stand-alone plant must be able to last the longest period without solar availability, even if it occurs once in a year.

One of the more revealing studies by Iannucci shows graphically the low utilization of long-term storage [7, 9]. In Figure 2-7, the percentage of baseload electrical demand satisfied by solar is plotted against storage duration in hours for an Albuquerque site with various collector field sizes expressed in critical solar multiples. The tradeoff between

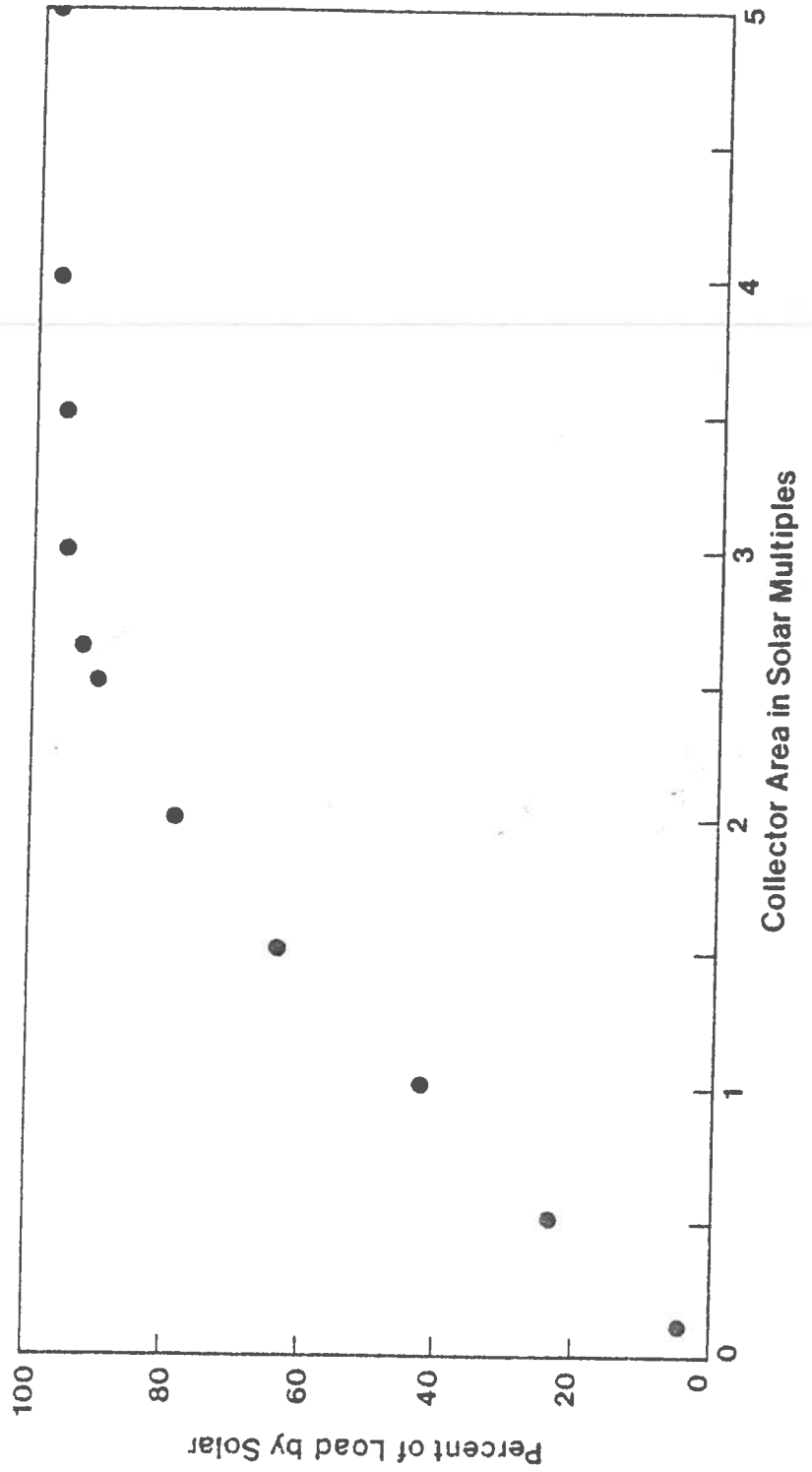

Figure 2-5. PERCENTAGE OF A HYBRID ELECTRIC POWER PLANT LOAD SUPPLIED BY SOLAR AS A FUNCTION OF COLLECTOR MIRROR AREA IN SOLAR MULTIPLES. (7)

BY SOLAR AS A FUNCTION OF COLLECTOR MIRROR AREA IN
SOLAR MULTIPLES (7)

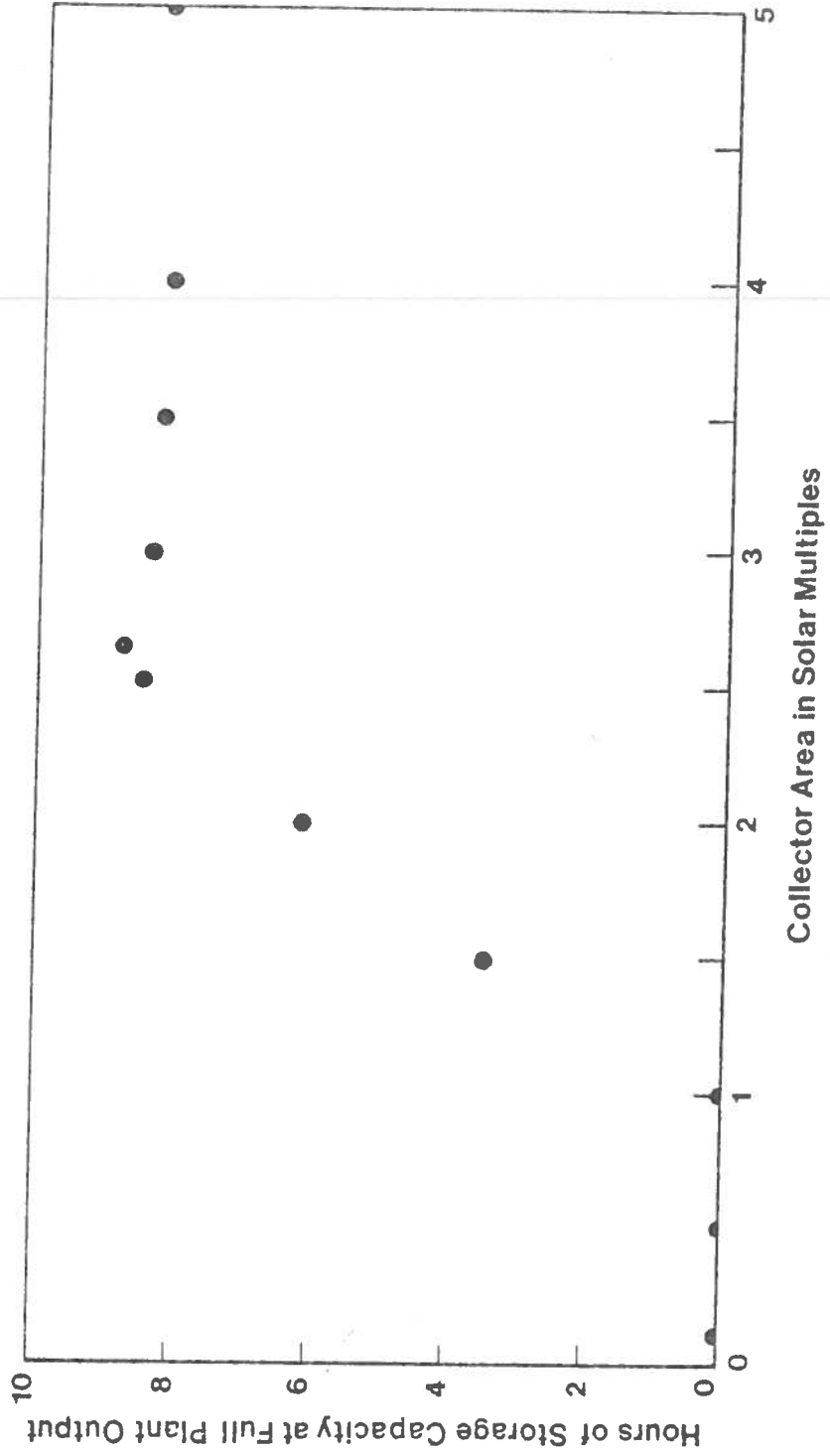
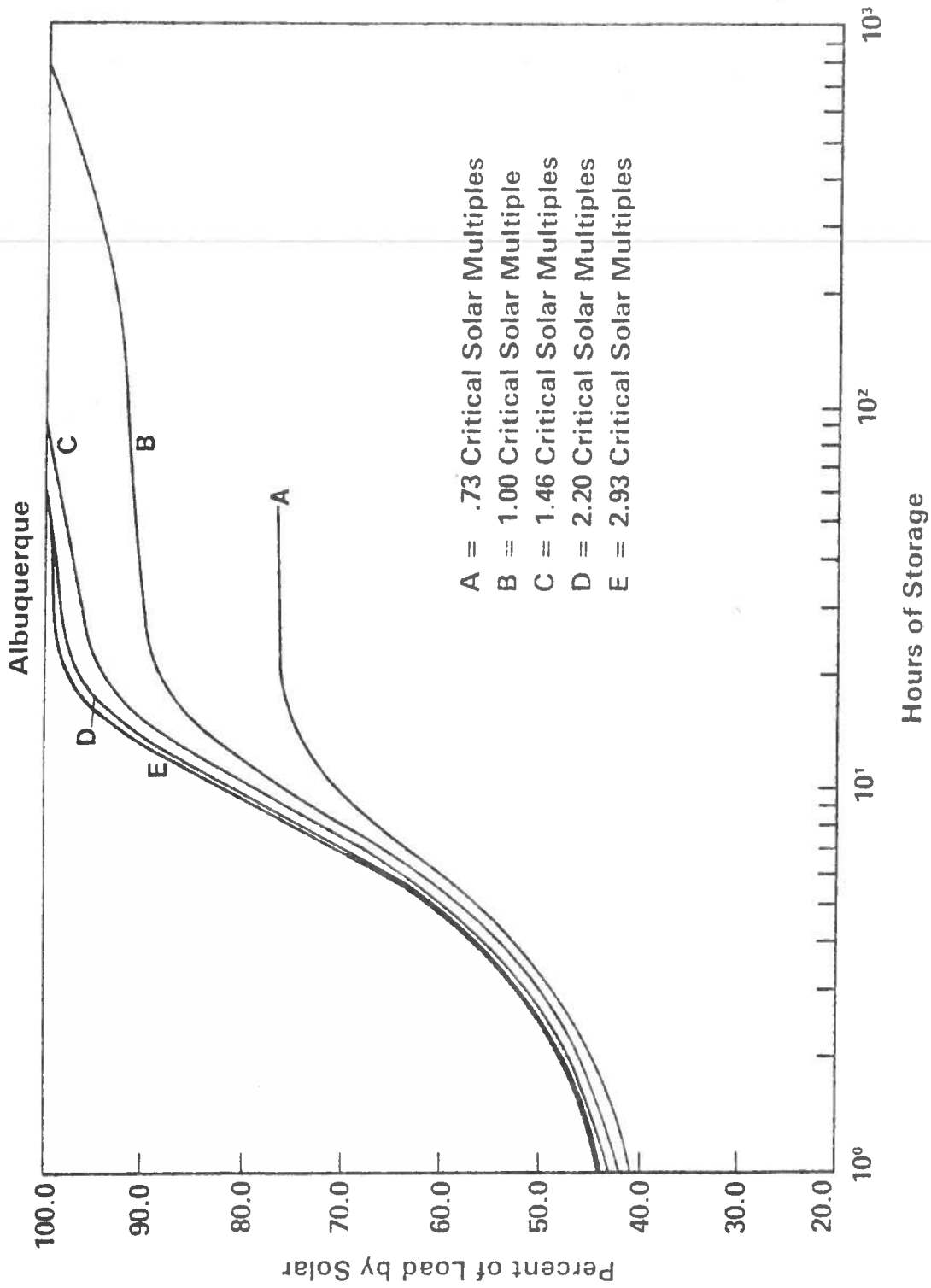

Figure 2-6. STORAGE CAPACITY FOR THE HYBRID ELECTRIC POWER PLANTS OF
FIGURE 2-5 AS A FUNCTION OF THE COLLECTOR MIRROR AREA
IN SOLAR MULTIPLES. [7]

TABLE 2-3

RELATIVE ELECTRICITY COSTS IN 2015 FOR A HYBRID SOLAR ELECTRIC PLANT
AS A FUNCTION OF THE COLLECTOR FIELD SIZE AND ASSOCIATED STORAGE [7]

Percent Satisfied by Solar	Solar Multiple	Receiver Size (MW _t)	Storage Charge Rate (MW _t)	Storage Capacity (Hours)	\$60/m ² Relative Electricity Cost	\$120/m ² Relative Electricity Cost
4.81	.1	20	0	0.	.97	.98
24.04	.5	100	0	0.	.86	.90
42.76	1.0	172	0	0.	.75	.83
48.19	1.5	182	0	0.	.74	.85
80.	2.0	398	161	6.1	.64	.79
92.	2.5	462	204	8.5	.60	.79
94.6	3.0	463	205	8.4	.61	.84
95.5	3.5	455	199	8.1	.63	.90
95.9	4.0	445	191	8.0	.66	.97
96.4	5.0	435	185	7.9	.73	1.11



A = .73 Critical Solar Multiple
 B = 1.00 Critical Solar Multiple
 C = 1.46 Critical Solar Multiple
 D = 2.20 Critical Solar Multiple
 E = 2.93 Critical Solar Multiple

Figure 2-7. EFFECT OF STORAGE DURATION ON PERCENT ENERGY PROVIDED BY SOLAR FOR VARIOUS COLLECTOR ARRAY AREAS IN ALBUQUERQUE [7]

collector field size and storage duration is obvious in this plot. For a given collector field, there is an initially linear relationship between percent solar and hours of storage up to enough storage to last overnight. Beyond 20 hours of storage, a point of rapidly diminishing returns occurs because the storage utilization is so low. To gain a few percent contribution by solar requires significant increases in storage beyond 20 hours. The maximum useful storage duration is 845 hours to provide 100% solar for a collector field size equal to the CSM. Similar trends in the storage-collector tradeoffs were found for other cities [7, 9].

In summary, the work cited suggests that a significant storage capacity is potentially desirable but that operation of a solar thermal power plant as an autonomous unit is not as economically attractive as hybrid operation for the storage reaction selected. At least enough storage capacity is required in an autonomous plant to last the longest period without insolation and sufficient collector area must be available to assure that the storage unit never completely discharges. The large storage capacity and collector area necessary to meet these needs were more costly in the study than a backup fossil fuel unit in the system and the utilization of the additional storage capacity and collector area is so low that their cost cannot be justified by the fuel savings. However, these results may not be universally applicable due to specific component costs used in the study. A far less expensive or more efficient storage system, cheaper collectors, a different alternative fuel than oil, or a different fuel price would probably alter these conclusions; but the studies demonstrate that long-term storage should be inexpensive. An analysis of the coupling between cost and efficiency goals illuminates the differences between daily and seasonal storage [10].

2.1.3 Analyses for Other Applications

The study by Løf and Tybout did not include sufficiently long storage durations to be considered seasonal storage. In such a case, the amount of solar energy collected exceeds the demand during the summer months, and a storage unit is charged with the excess energy. In the winter months, the demand by the load is greater than the amount of solar energy collected, and the storage unit slowly discharges. Sufficient storage capacity is provided to prevent the storage unit from completely discharging at the end of the winter before the net charge cycle begins again and no backup unit is required. The storage capacity for seasonal operation is significantly greater than those discussed by Løf and Tybout, but the optimum collector field size would probably be less. As a result, the cost of delivered energy could go through a second minimum for large storage capacities provided storage is very inexpensive. A detailed systems study similar to that of Iannucci is required to establish how the energy costs at that minimum relate to the energy costs for the solutions investigated.

Although the study by Iannucci provides a valuable first step in defining the role of long-term storage for electric utilities, an important question in the solar powered electric plant study is whether it is realistic to consider building a stand-alone plant. It is more likely that the solar plant would be part of a grid composed of a mixture of nuclear, oil, gas, and coal plants. Some of these plants would be used to meet short-term peak

electrical requirements while other baseload plants would supply the power demand which is constant 24 hours a day. The baseload plants tend to be high capital cost, low fuel cost nuclear or coal plants while the peaking units are usually low capital cost, high fuel cost fossil plants. The location and function of a solar plant within this grid must be defined by a system study which considers the entire network.

The optimum type and location of storage for electric power plants must also be defined in the context of the entire grid. For example, storage could be located between the electric generator and user in Figure 1-1, and the device could store excess power for the entire mix of generating units—not just solar. Storage in this role would take excess baseload capacity in off-peak hours and make that energy available in times of peak demand, thereby, reducing the consumption of expensive fossil fuels. Pumped storage units currently provide just this capability. If the solar plant generates excess electricity during certain load periods, it could be stored in the grid storage unit for later distribution. However, as mentioned in Section 1.0, storage of excess solar energy as electrical energy rather than thermal energy results in lower utilization of the turbines and generators in Figure 1-1; and these units must be larger to produce the same amount of energy.

Other important solar applications exist besides home heating and electric power generation. For example, industrial energy users consume 27% of the total U.S. energy demand (20 quads) as process heat. About 22% (4.4 quads) is used at temperatures below 180°C (350°F) and 30% (6.0 quads) below 290°C (550°F) [11]. These temperatures are considered accessible by current solar collector technology. However, storage is not considered economically attractive now if an oil or gas backup is available because of the large capital outlays required. For instance, if a plant runs 24 hours a day at a constant load, it requires at least three times as much collector area to service the entire load with sixteen hours of storage as it does to supply energy just during daylight hours with minimal storage and an oil backup. Therefore, the capital cost, which is substantial anyway, is about three times as high. Industrial users with an oil or gas backup tend to favor only enough storage to withstand transients in operation. When the cost of solar energy becomes less than for the backup fuels, more storage will become attractive.

In order to accurately define the optimum role of storage in any application, detailed system studies are required. However, some generalizations are possible based on the studies cited. If the load requirements are generally constant over time and the collected energy costs are marginal, it will probably be cheaper to use a backup energy source than storage for long periods without solar since the stored energy requires extra collector field as well as storage. If the demand is highest during sunny periods, this argument still applies. In either case, storage will only have a potential economic role if the cost of delivered energy is cheaper from solar collectors than from an alternate source. On the other hand, if the load requirements and solar availability are out of phase as in home heating, storage actually improves the system economics since it allows better utilization of equipment.

Another exception occurs if the collector field lies idle frequently during periods of high solar insolation such as home heating systems in the summer or five-day work week

process heat facilities on the weekends. In this case, storage could actually improve the overall economics since extra solar energy can be delivered with the storage system being the only additional cost. No increase in collector field size (and cost) is necessary, and the size may in fact actually decrease since the stored energy could be used in place of collected energy.

Hooper has suggested such a shift in collector area for home heating in northern latitudes although, since the utilization of storage is low, the storage costs must be minimal for this tradeoff to be economical [12]. In a five-day week process heat application, the above tradeoff is more likely to be attractive since the stored energy utilization could be high. For example, 16 hours of energy could be stored over a cloudless weekend and used on a Monday night for a plant operating 24 hours a day, five days a week at a constant rate. Provided most weekends are cloudless, the utilization is high. The actual storage utilization will depend on the plant operation and the weather patterns. The next section will discuss the impact of storage utilization more fully.

2.2 THE COST OF STORED ENERGY

The total cost of a thermal energy storage unit can be determined from the cost of the total storage capacity (energy related costs) and the cost of energy removal or addition (power related costs).

$$\text{Total Cost} = \text{Energy Related Cost} + \text{Power Related Cost} \quad (1)$$

Storage capacity costs include the costs of the storage medium, container, insulation, and any other items used for the actual storage of heat. The power related components are such items as heat exchangers, pumps, plumbing, heat transfer fluids, and any other device needed to transfer heat for the storage unit.

The total storage cost can also be related to the energy storage capacity and the power capability from storage by:

$$\begin{aligned} \text{Total Cost} = & (\text{Energy Storage Capacity}) (\text{Storage Capacity Cost}) \\ & + (\text{Power Capability}) (\text{Power Capability Cost}) \end{aligned} \quad (2)$$

The unit costs must be determined for the given storage capacity and power capability since economies-of-scale can cause a decrease in unit price and changes in unit configuration can result in discontinuities in the unit price [13].

In order to minimize the system cost given by Equation 2, the power capability and energy storage capacity would be kept as small as possible and still provide adequate energy transfer and the necessary storage duration time T:

$$T = \frac{\text{Energy Storage Capacity}}{\text{Power Capability}} \quad (3)$$

For a device to provide long-term or seasonal storage, T will be generally very large. The energy storage capacity will be much larger than the power capability, and the energy related costs will generally dominate the total system cost of Equation 2. Therefore, for a long-term storage device, it is necessary to find very inexpensive storage materials, containers, and other capacity related items while the heat exchangers and other power related components can be relatively expensive. On the other hand, for a short-term storage unit which must only handle brief periods of cloud cover (small T in Equation 3), the power related costs will generally dominate and the power capability unit costs must be kept low to minimize the system cost. The unit energy capacity cost can now be higher than for the seasonal storage without substantial impact on the total cost. Of course, regardless of the cost breakdown, the total storage system cost must be low enough to fit the application.

2.2.1 The Effect of Storage Utilization

To conceptualize the impact of the total energy storage cost on delivered energy costs, the energy in a storage device is broken down into fictitious elements according to useage. A solar installation is considered in which the demand is regular and independent of the season. With minor variations, the final conclusions should apply to any system, however.

Initial blocks of storage added to the system are used nightly and during periods of cloud cover, and substantial amounts of energy pass through these elements of storage. Eventually, a point is reached where additional blocks of storage are only useful at night. Once enough storage is available to last the shortest night, additional storage elements are only discharged during longer nights in the year and cloudy periods which follow sunny days. Storage blocks beyond those required to last the longest night are used less since cloudy and sunny days rarely alternate in a regular pattern. This diminishing utilization of additional storage elements continues until enough storage is added to provide a 100% solar powered system. Any storage beyond that amount is not used at all. Figure 2-8 presents an idea of how the storage element utilization might change as elements are added.

The degree of utilization of storage discussed above has important consequences on the price of the energy delivered from the storage subsystem. For example, suppose a price of $\$3/\text{kW}_t\text{-hr}$ of capacity is projected for a thermal storage system. If 20% of that cost will cover yearly charges for operation and maintenance, income taxes with straight line depreciation, and the return on investment, the yearly cost of the unit is about $\$0.60/\text{kW}_t\text{-hr}$. If the device is used 300 times per year to meet evening loads and periods of cloud cover, the cost of the energy due to the storage unit price is about:

$$\frac{\$0.60/\text{kW}_t\text{-hr-yr}}{300 \text{ uses/yr}} = \$0.002/\text{kW}_t\text{-hr} (\$0.586/\text{MBtu}) \text{ delivered.} \quad (4)$$

This cost is only that associated with storage and neglects the price of collectors hardware, etc. required to charge the unit. The cost is low enough that storage is not a

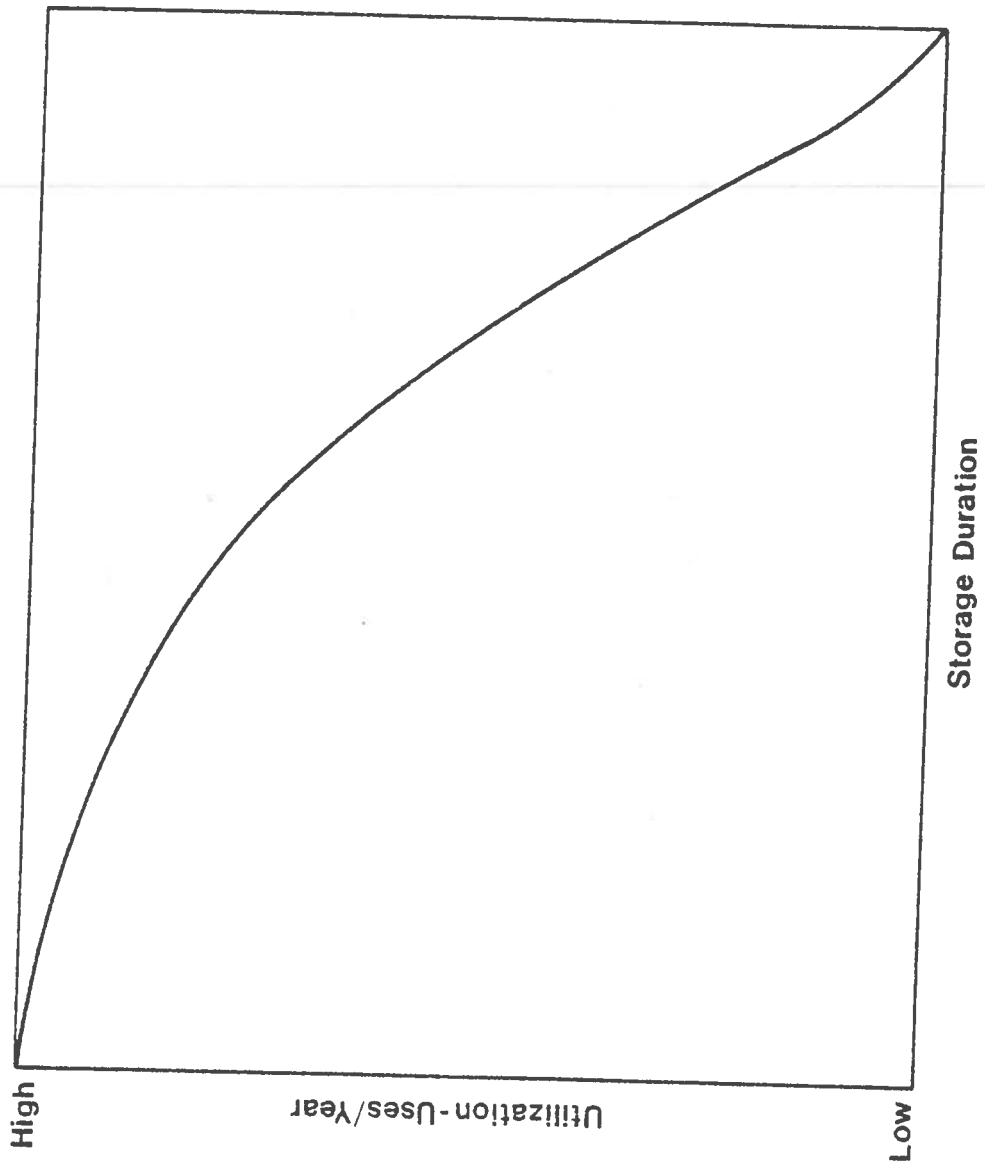

Figure 2-8. POSSIBLE UTILIZATION OF LAST ELEMENT OF STORAGE ADDED VERSUS THE STORAGE DURATION TO THAT POINT

major cost barrier in many applications for such high utilization. If the cost of collectors required to charge storage is low enough, the total delivered energy cost could be attractive.

If the storage block added to meet extended cloudy periods is examined, its utilization is far less. Perhaps this fictitious block of storage would be used only four times per year. With the same capital recovery factor as above, the cost of energy delivered from this element is approximately:

$$\frac{\$0.60/\text{kW}_t\text{-hr-yr}}{4 \text{ uses/yr}} = \$0.15/\text{kW}_t\text{-hr} (\$43.95/\text{MBtu}) \text{ delivered.} \quad (5)$$

When the costs of collectors, hardware, etc., are added, the delivered energy cost for this case is not promising. Furthermore, for a utility the costs must be divided by the efficiency of thermal to electric generation to obtain the cost for electricity. Thus, if the average number of uses of total storage capacity is low, it is critical to develop very low cost storage subsystems such as aquifers with projected first costs of about $\$0.01/\text{kW}_t\text{-hr}$ capacity or less. In all cases, a complete study of the entire solar system with storage is required to clearly establish the economics of the delivered energy.

2.2.2 The Effect of Storage Efficiency

The fraction of the energy used to charge storage which can be delivered to the load at the required rate (efficiency) has important consequences on the delivered energy cost. First, the amount of storage materials must be increased beyond the minimum theoretically required. For example, if 67% of the energy put into storage can be actually delivered to the load, then 50% more storage capacity must be provided to allow for these losses. Thus, the energy related cost is about 50% higher than if the same device were 100% efficient.

The efficiency has perhaps more important consequences on the collector cost. To provide the "lost" energy, the collector area must also be increased beyond the theoretical minimum. Returning to the example above, the energy output from the collector field to storage must be 50% greater than that from the storage device. As a result, the collector field cost is higher than the minimum possible. The cost of the energy from storage will be considerably higher in this instance since not only must the minimum collector field and storage capacity be paid for, but the cost of the extra components must be covered as well. As a result, low efficiency storage systems will probably not provide competitively priced energy unless both collector and storage costs are very low—an event not likely to occur in the immediate future—or excess energy available at one time can be provided during periods of high demand, thereby reducing collector size.

In considering energy storage costs, the penalty associated with the delivered energy temperature must also be taken into account. If a process requires heat input at a temperature T , the collector field must operate at a higher temperature $T + \Delta T$ in order

to transfer heat to the process. However, if a storage subsystem is incorporated between the collector and the load, allowances must be made for temperature drops between the collector field and storage and between storage and the load. The collector field must operate at a higher temperature, perhaps at $T + 2\Delta T$. To further complicate matters, some storage media go through a continuous temperature drop as they are discharged (sensible heat liquids) or must undergo a temperature decrease to release energy (reversible chemical reactions).

The lowest storage temperature during discharge must be higher than that required by the load while the collector field temperature must be above the highest storage temperature required during charging. Consequently, the collector field will operate at a temperature considerably higher than the load requirements. In each instance, an increase in collector temperature results in a decrease in collector efficiency and the field size (and cost) will increase accordingly. In some instances, it may be necessary to use a collector designed for temperatures higher than the actual load requirements, usually with a higher cost. Alternatively, if the heat is converted to work, the process will operate with a lower efficiency. The magnitude of the effect of temperature on the system cost and performance depends upon the nature of the collector efficiency or the type of work cycle utilized.

SECTION 3.0

THERMAL STORAGE METHODS AND MEDIA

Thermal energy is stored as a change in internal energy of a material through shifts in sensible heat, latent heat, heat of reaction, or combinations of these. In general, it is desirable to use materials which possess a large change in internal energy per unit volume to minimize the space needed to store energy. To be economically competitive in commercial solar systems, it is important to employ substances with a high internal energy change per unit cost. Other properties such as vapor pressure, toxicity, and corrosiveness also must be considered since they influence the price of material containment in commercial systems. In this section, thermal storage methods, material costs, and some of the important properties which influence thermal storage costs will be reviewed for some presently considered thermal storage media. The equally important questions of containment and heat exchange will be addressed later.

3.1 SENSIBLE HEAT STORAGE

Raising the temperature of a solid or liquid is the simplest way to store thermal energy. Most thermal storage devices now in operation utilize sensible heat storage since current technology is generally adequate for good system design. The amount of energy stored, Q , is equal to the integral of the specific heat, C_p , between the peak and minimum temperatures (temperature swing) experienced by the storage media:

$$Q = \int_{T_1}^{T_2} C_p \, dT \quad (6)$$

The peak temperature T_2 is fixed by the collector capabilities while the low temperature T_1 is determined by the temperature required by the load. The material chosen must be thermally stable and undergo no phase change between the temperature extremes. The substance should also have a high heat capacity, high density, and an acceptably low vapor pressure. Finally, it must be inexpensive.

The energy storage capacities per unit volume of selected liquids for sensible heat storage are shown in Figure 3-1 as a function of the temperature swing of the storage media between the temperature limits of the liquid shown in Table 3-1. The heat capacity data used to construct Figure 3-1 was quite accurate. However, an average mass density was employed to give a feel for the volumetric energy storage capacities since exact density data yields values which are only meaningful relative to a specified lower operating temperature. For system design, more accurate data should be used. But for the comparisons made here, this data should be sufficient.

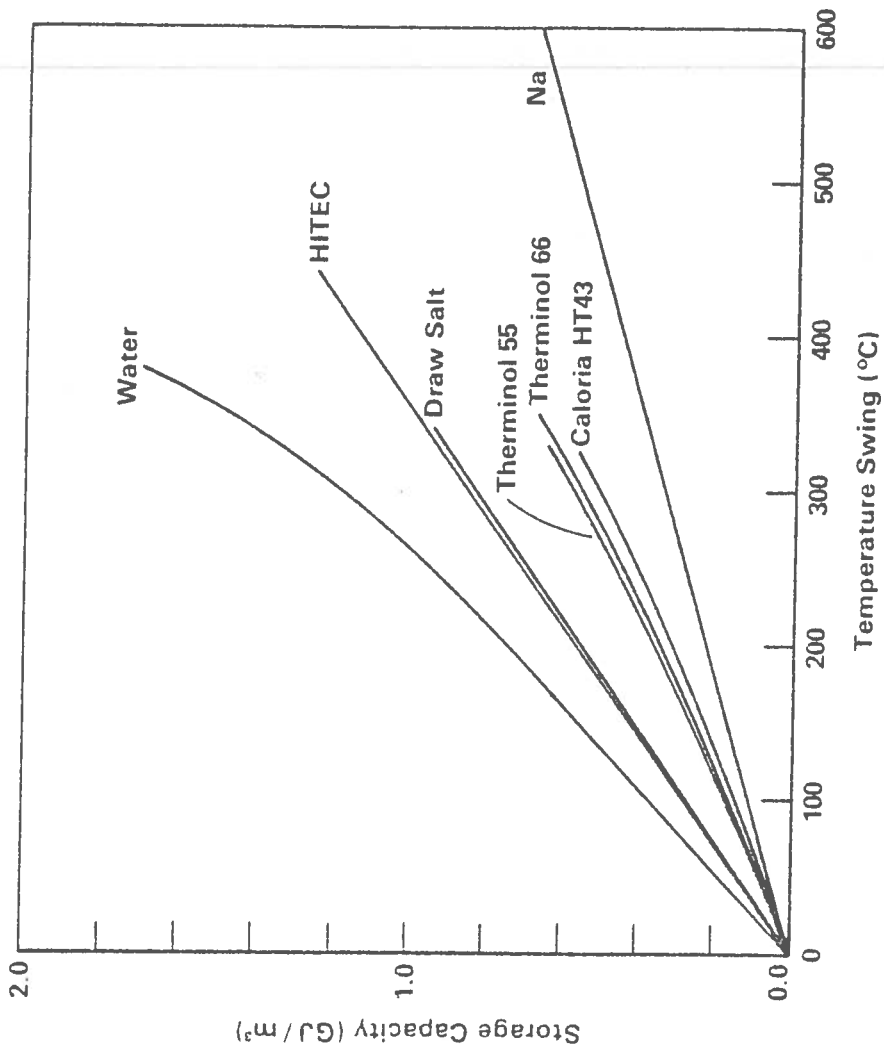

Figure 3-1. STORAGE CAPACITY PER UNIT VOLUME AS A FUNCTION OF TEMPERATURE SWING FOR SELECTED LIQUID SENSIBLE HEAT STORAGE MEDIA

Table 3-1

SELECTED LIQUID SENSIBLE HEAT STORAGE MEDIA

Medium	Fluid Type	Cost (\$/kg)	Temperature Range (°C)	Heat Capacity (J/kg °K ⁻¹)	Comments
Water	---	.00	0 to 374	4190	Pressure vessel required above 100°C.
Caloria HT43	Oil	.30	-9 to 316	2300	Cracking occurs at high temperatures and may form volatile products lowering flash point. May polymerize at high temperatures to increase viscosity. Nonoxidizing environment required at high temperature.
Therminol 55	Oil	.60	-18 to 316	2400	
Therminol 66	Oil	2.03	-9 to 343	2100	
Hitec	Molten Salt	.59	150 to 590	1550	Long-term stability unknown above 550°C. Stainless steel or other expensive containers probably required above 450°C. Inert atmosphere required at high temperatures. Heated lines required to prevent freezing.
Draw Salt	Molten Salt	.44	250 to 590	1550	
Na	Liquid Metal	.90	125 to 760	1300	Stainless steel or suitable alternate containers required. Requires sealed system. Reacts violently with water, oxygen, and other materials.

Figure 3-2 shows the storage media capacity cost in dollars per MJ of energy stored for the same liquids. Prices are for 1978 and were determined for very large quantities of materials from manufacturer's quotes for commercial fluids or from values given in the Chemical Marketing Reporter [14]. For the latter materials, commercial grades are assumed to be acceptable without special purification. The price of water is for Denver and may almost be considered as free. The cost of containers, heat exchangers, etc. are not included in these comparisons.

Water appears to be the best sensible heat storage liquid available since it is inexpensive and has a high specific heat. However, antifreeze must be added to water if the fluid temperature can drop below 0°C , and this adds significantly to the system costs. A heat exchanger between storage and the heat transfer fluid for the collectors can eliminate the need for antifreeze in the storage used but at the expense of more equipment. Above 100°C , the storage tank must be able to contain water at its vapor pressure and the storage tank cost not included in Figure 3-2 rises sharply with temperature beyond this point. Water cannot be economically employed above its critical point of 374°C . Organic oils, molten salts, and liquid metals circumvent the vapor pressure problems and appear more desirable for high-temperature storage. But significant limitations in handling, containment, storage capacities, cost, and useful temperature range are evident for each as shown in Figures 3-1, 3-2, and Table 3-1 [15-17]. Although these fluids are used in commercial operations, the lifetime and cost requirements for solar storage make them somewhat less desirable in this application.

The difficulties associated with the vapor pressure of water and the limitations of other liquids can be avoided by storing thermal energy as sensible heat in solids. Many inorganic solids are chemically inert even at high temperatures. Larger amounts of solid are generally needed than for water since the heat capacity of the solids is less as shown in Figure 3-3. Figure 3-3 was prepared on the same basis as Figure 3-1 except that all the temperatures are relative to a lower limit of 0°C . The cost of the storage media alone per unit energy stored, although not as low as water, is still acceptable for rocks as shown in Figure 3-4. This figure was prepared on the same basis as Figure 3-2. In fact, the cost of water and rocks are low enough that the storage costs are influenced more by the price of containers, heat exchangers, and other auxiliary items than by the storage materials themselves.

Direct contact between the solid storage media and a heat transfer fluid is desirable to minimize the cost of heat exchange in a solid storage medium, and the storage volume must be increased beyond that of Figure 3-3 by up to 50% to allow fluid passage. Thus significant container volumes are required. While air is generally acceptable as a heat transfer fluid for rocks in low-temperature home heating systems, other fluids such as high pressure helium or heat transfer oils are generally required in high-temperature installations to provide adequate heat transfer capability [17, 18]. The heat transfer fluid must also be compatible with the solids, and the problems associated with finding a fluid with low vapor pressure, high heat capacity, and low cost are similar to those for storage in a liquid.

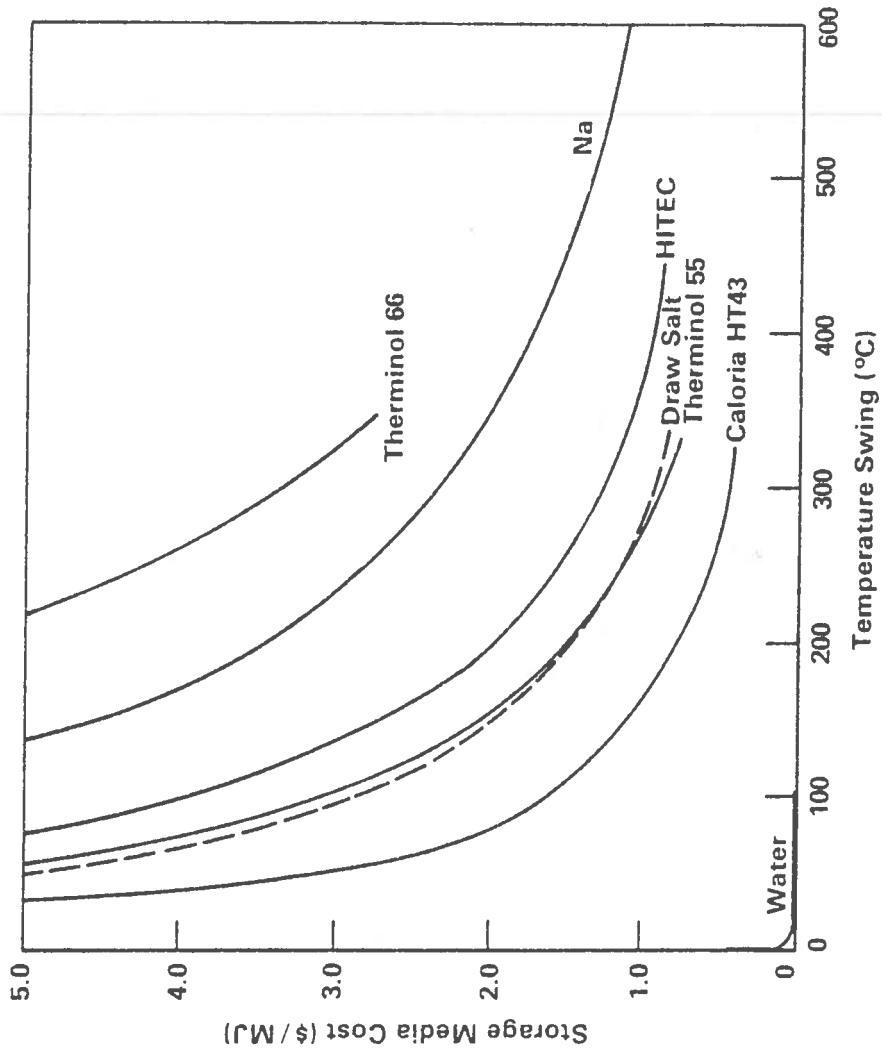

Figure 3-2. STORAGE MEDIA COSTS IN DOLLARS PER UNIT ENERGY STORED AS A FUNCTION OF TEMPERATURE SWING FOR SELECTED LIQUID SENSIBLE HEAT STORAGE MEDIA

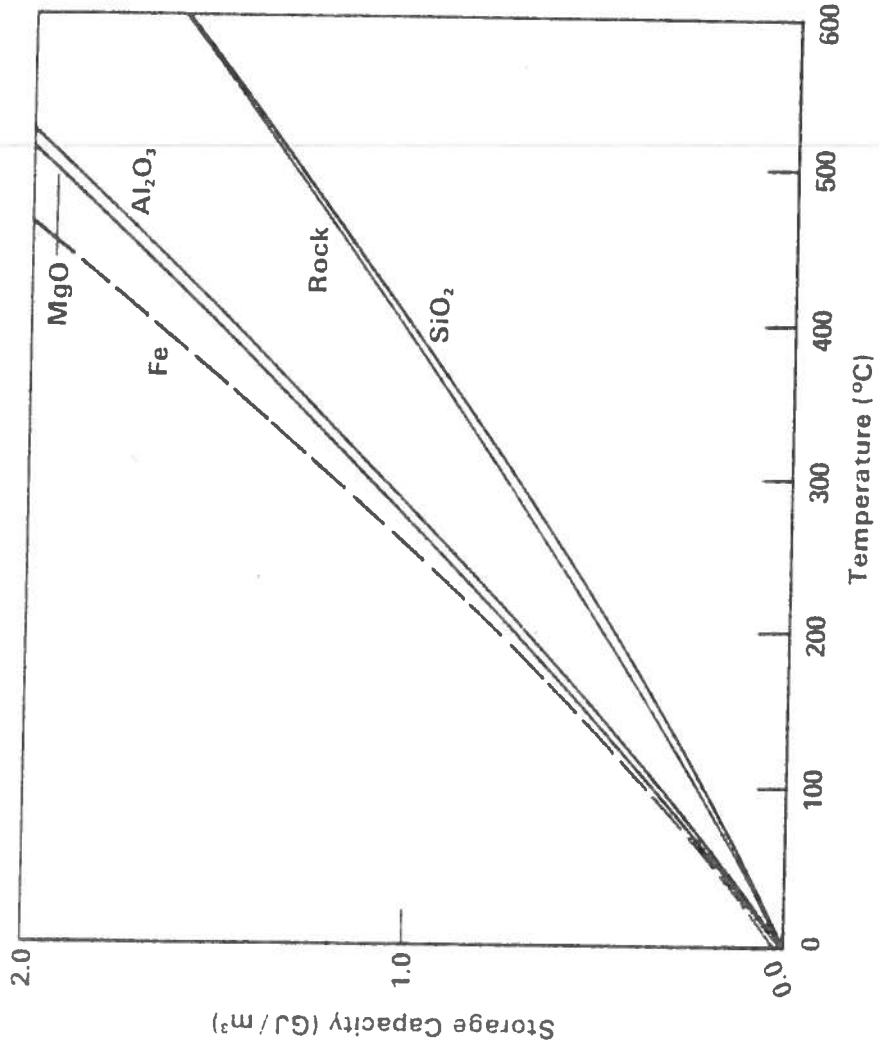

Figure 3-3. STORAGE CAPACITY PER UNIT VOLUME AS A FUNCTION OF TEMPERATURE FOR SELECTED SOLID SENSIBLE HEAT STORAGE MEDIA

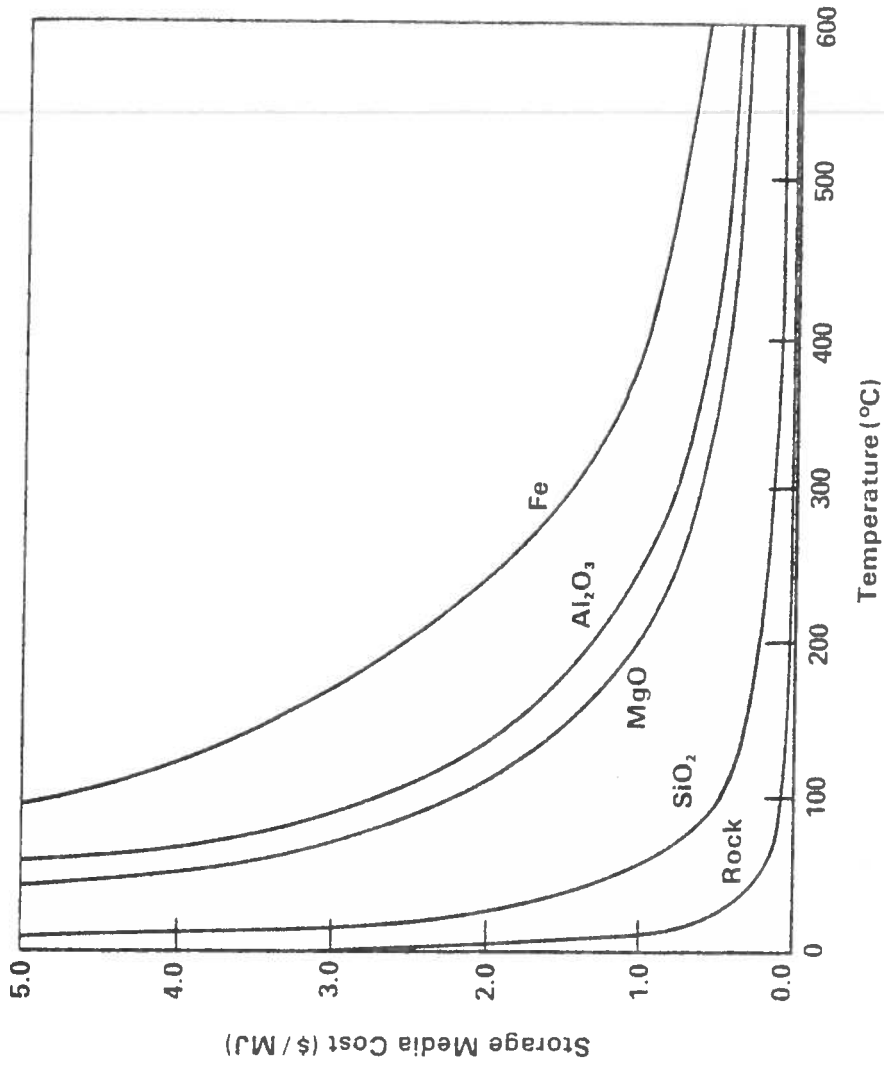

Figure 3-4. STORAGE MEDIA COSTS IN DOLLARS PER UNIT ENERGY STORED, AS A FUNCTION OF TEMPERATURE FOR SELECTED SOLID SENSIBLE HEAT STORAGE MEDIA

3.2 LATENT HEAT STORAGE

A substantial change in internal energy generally accompanies a phase change from solid to liquid or from liquid to gas at a characteristic temperature. Such high energy storage densities over a narrow temperature range make latent heat materials attractive for thermal energy storage. Since a high volumetric energy storage density is essential, only solid-liquid or possibly solid-solid transformations with significant enthalpy changes are of practical interest.

The literature on selection of low-temperature latent heat storage materials is extensive with the representative summaries available in References [19] and [20]. Material requirements include low cost, high heat of transition, high density, appropriate transition temperature, low toxicity, and long-term performance. Paraffin waxes [21] and salt hydrates [19] have been favored for low-temperature storage although the former are flammable while the latter are prone to liquid subcooling without crystallization. The volumetric energy densities of these materials are higher than for water, particularly for small temperature swings about the fusion temperature, as shown in Figure 3-5. Constant densities and heat capacities have been used to prepare Figure 3-5 and this figure should only be used for the purposes of comparison. The lower temperature limit of 0°C was selected arbitrarily for the low-temperature materials. Some of the volume advantage of low-temperature phase change materials relative to sensible heat storage in water is sacrificed, however, in current systems since up to 50% more volume is required than shown in Figure 3-5 to allow for passage of a heat transfer fluid.

Figure 3-6 presents the relative storage capacity costs for commercial paraffin wax and sodium sulfate decahydrate. Once again, only the storage material cost is included in the plot. The price of sodium sulfate decahydrate is low enough to be attractive, but containment by conventional methods causes the cost of an entire system to be higher than for water. The transition temperature is also somewhat low for home heating purposes, and large amounts of a heat transfer fluid would have to be circulated through the storage system. Continued work on improving the freezing process and developing new heat exchange concepts may overcome some of these obstacles. The costs of the other salt hydrates and paraffin wax are generally higher and these materials will likely only be competitive with the price of water storage if very low cost heat exchangers and containers are developed.

For higher temperatures, some generalizations are possible about latent heat materials [22]. Carbonates and possibly carbonate-chloride systems are serious storage candidates because their good corrosion characteristics make them inexpensive to contain and their cost is reasonable. Nitrates and nitrites are good choices for applications below 500°C since they are relatively noncorrosive and fairly inexpensive. Chloride systems are cheap enough to be attractive but are more corrosive than the previous compounds. Hydroxides as a group tend to be both more expensive and corrosive. Fluorides offer relatively high heat storage densities, but they are often expensive and their corrosive nature make the fluorides more expensive to contain than the other salt systems discussed above.

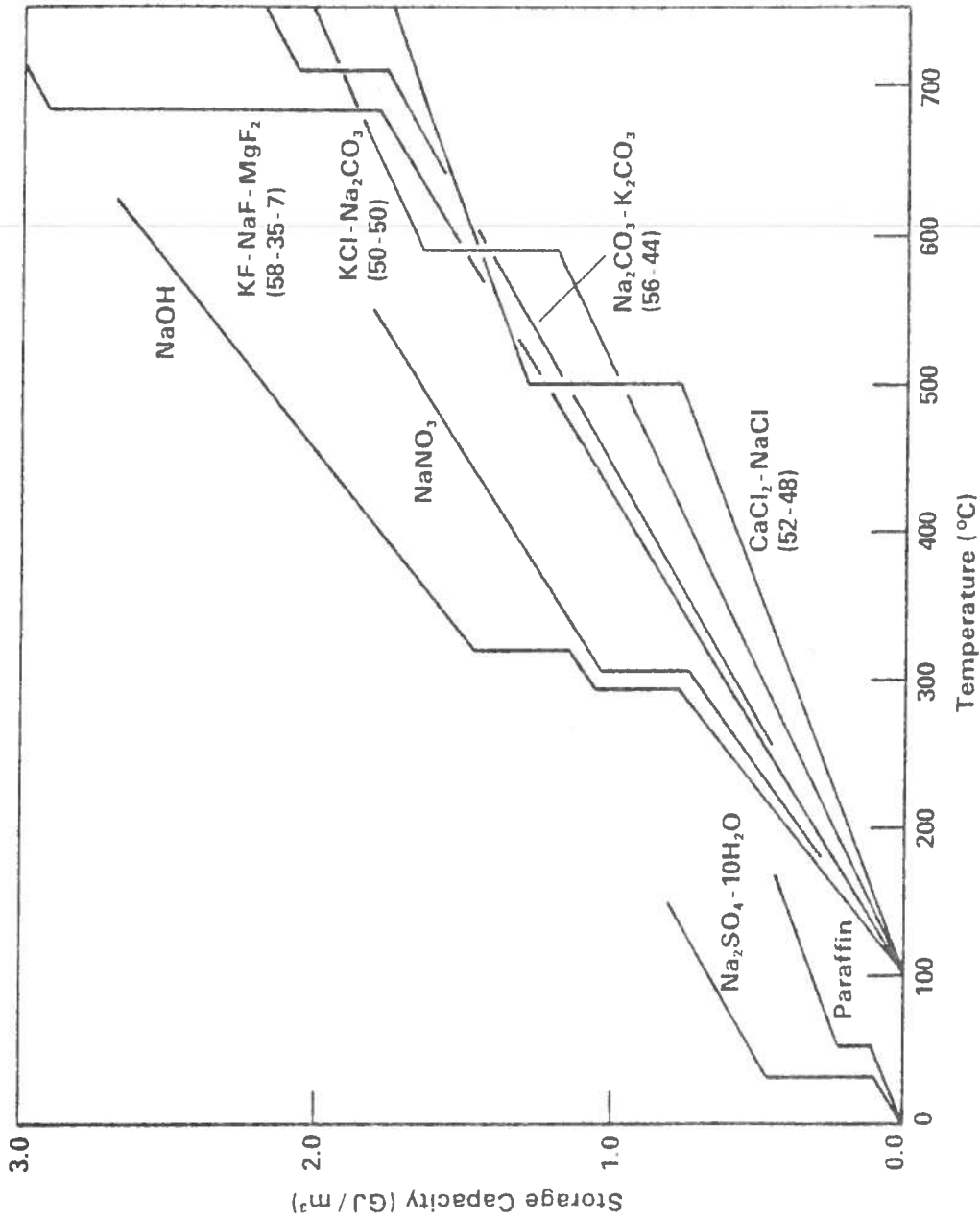

Figure 3-5. STORAGE CAPACITY PER UNIT VOLUME AS A FUNCTION OF TEMPERATURE FOR SELECTED LATENT HEAT STORAGE MATERIALS. THE MOLAR COMPOSITION OF MIXTURES ARE SHOWN IN PARENTHESES

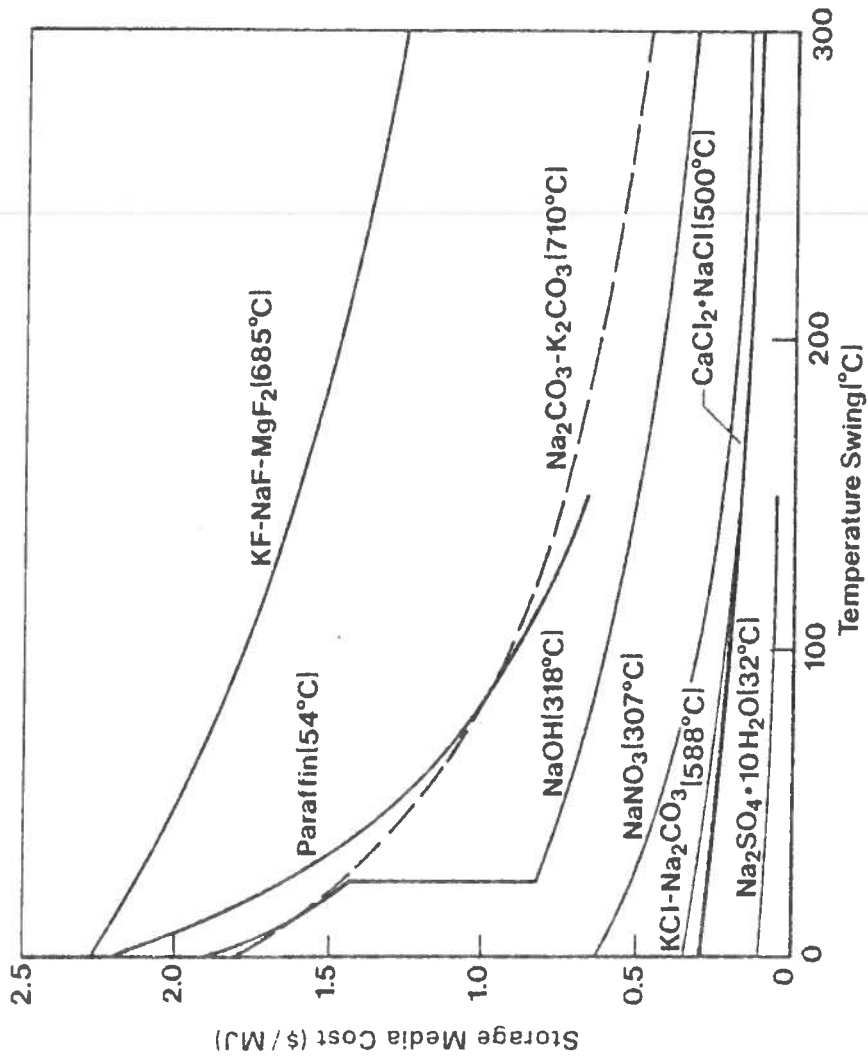

Figure 3-6. STORAGE MEDIA COSTS IN DOLLARS PER UNIT ENERGY STORED AS A FUNCTION OF TEMPERATURE SWING FOR SELECTED LATENT HEAT STORAGE MATERIALS. THE FUSION TEMPERATURE IS IN PARENTHESES

Figure 3-5 presents the volumetric energy storage density for high-temperature storage salts of the types discussed. The lower temperature limit was arbitrarily chosen as 100°C to avoid confusion with the low-temperature materials. The density of the liquid phase near the transition temperature of the material was used to transform the data of Reference [22] to a volume basis for this plot because sufficient volume must be provided to contain the lower density melt. Mixtures of salts were used in some cases to provide a lower transition temperature than the pure materials, and the densities were computed assuming the compound volumes were additive. The composition of the mixtures by mole percentage are shown in parenthesis on the plot. Since constant properties were used and several approximation were employed to estimate properties, the plot should only be used as a rough means to compare materials and not as a basis for engineering design. The two sharp increases in energy storage density exhibited by sodium hydroxide are due to a solid-solid phase change within about 25°C of the solid-liquid transformation. Again, a volume penalty must generally be assessed against the storage densities shown to allow heat transfer for the phase change.

Figure 3-6 presents the storage media capacity costs as a function of the temperature swing about the transition temperature shown in parenthesis. The assumption is again made that commercial grade materials are acceptable. The costs of some of the salts shown are competitive with the costs of sensible heat liquids for high-temperature storage, but significant problems in containment, heat exchange and in some cases, corrosion must be overcome to make latent heat storage systems cost-effective. In addition, extra charges may be necessary to purify these materials to grades acceptable for thermal storage.

3.3 REVERSIBLE REACTION STORAGE

Thermal energy may also be stored as the bond energy of a chemical compound and energy can be repeatedly stored and released in the same materials by means of reversible chemical reactions. Thermal energy from a source is absorbed under conditions which favor significant conversions to a high enthalpy chemical species by an endothermic forward reaction. The reaction can only proceed until the equilibrium concentrations are reached. Then, the conditions are altered to favor high conversion by the exothermic reverse reaction to the low enthalpy species and energy is released. The equilibrium concentrations of the species may be altered by: (1) changing the concentration (or pressure) of the chemical species and/or (2) changing the temperature of these species.

The energy storage densities of reversible chemical reactions are generally higher than for heat-of-fusion transitions. Chemical storage also has significant cost potential since some of the materials could be available for as little as a few pennies per pound. Chemical storage has the added advantage in that significant energy storage densities are possible even at ambient conditions. However, as will be shown in Section 5.0, careful heat exchange between products and reactants is required for some applications to minimize sensible heat losses and provide efficient storage of energy.

A number of potential applications for chemical storage exist, particularly due to the capability to store energy at ambient conditions. Long-term storage of energy is possible with minimal loss of energy to the environment during storage. Heat can be pumped from the environment by some reactions. A transportable fuel could be produced in sunny locations by a suitable reaction for use in cloudy sections of the country. The reactants might also be used as a renewable fuel for automobiles.

Despite all the promise offered by chemical reaction storage, the technology is at an early stage of development and systems are not yet available for use in commercial applications. Relatively little experience has been compiled in the laboratory, and no significant scale demonstration units have been run. Research and development efforts are therefore needed for most systems to establish:

- reversibility of reactions with minor degradation of the chemical species (and catalysts, when required);
- satisfactory kinetics, specificity, and conversions of the reactions;
- acceptable heat transfer rates in cost-effective containers and/or heat exchangers;
- low cost storage and transportation (when required) of the chemical species;
- no excessive corrosion;
- sufficient energy storage densities; and
- acceptable storage efficiencies.

Reasonable cost projections will have to await further research to clarify the design of storage systems.

3.3.1 Thermochemical Storage Reactions

Three operating concepts are currently considered for reversible reactions: thermochemical storage, chemical heat pump storage, and thermochemical pipeline thermal transport. Table 3-2 presents a few of the possible reactions considered suitable for thermochemical storage [23-25]. The heats of reaction are calculated at 25°C from standard tables [26]. Since a high energy storage density is important, only reversible reactions with reactants and products which can be easily stored as liquids and solids are of practical interest, and some reactions obviously satisfy this criteria better than others. Reactions which produce two distinct phases such as a solid and a gas are desirable since the separation of products to prevent back reaction is facilitated. For example, solid calcium hydroxide (slaked lime) will endothermically decompose to solid calcium oxide (quicklime) and water vapor if it is heated to about 520°C at one atmosphere pressure. The water vapor is condensed for storage in a separate vessel.

Table 3-2

THERMOCHEMICAL STORAGE REACTIONS

Reaction	$\Delta H^\circ, \text{kJ}$	T^*, K
$\text{NH}_4\text{F}(\text{s}) \rightleftharpoons \text{NH}_3(\text{g}) + \text{HF}(\text{g})$	149.3	499
$\text{Mg}(\text{OH})_2(\text{s}) \rightleftharpoons \text{MgO}(\text{s}) + \text{H}_2\text{O}(\text{g})$	81.06	531
$\text{MgCO}_3(\text{s}) \rightleftharpoons \text{MgO}(\text{s}) + \text{CO}_2(\text{g})$	100.6	670
$\text{NH}_4\text{HSO}_4(\text{l}) \rightleftharpoons \text{NH}_3(\text{g}) + \text{H}_2\text{O}(\text{g}) + \text{SO}_3(\text{g})$	337	740
$\text{Ca}(\text{OH})_2(\text{s}) \rightleftharpoons \text{CaO}(\text{s}) + \text{H}_2\text{O}(\text{g})$	109.26	752
$\text{BaO}_2(\text{s}) \rightleftharpoons \text{BaO}(\text{s}) + 1/2 \text{O}_2(\text{g})$	80.79	1000
$\text{LiOH}(\text{l}) \rightleftharpoons 1/2 \text{Li}_2\text{O}(\text{s}) + 1/2 \text{H}_2\text{O}(\text{g})$	56.7	1000
$\text{CaCO}_3(\text{s}) \rightleftharpoons \text{CaO}(\text{s}) + \text{CO}_2(\text{g})$	178.06	1110
$\text{MgSO}_4(\text{s}) \rightleftharpoons \text{MgO}(\text{s}) + \text{SO}_3(\text{g})$	287.6	1470

When heat is required from storage, water and the calcium oxide are mixed, and the exothermic reverse reaction of the two species produces energy [27-29]. The operating requirements for this reaction will be discussed in more detail in Section 5.0.

The "turning temperature" T^* in Table 3-2 is defined as the temperature for which the equilibrium constant is one and is approximated by the ratio of the standard enthalpy change to the standard entropy change for the reaction [24]:

$$T^* = \frac{\Delta H^\circ}{\Delta S^\circ} \quad (7)$$

At this temperature, the reactants and products will be present in approximately equal quantities with the actual concentrations determined by the stoichiometry of the reaction. When $T > T^*$, the endothermic storage reaction is favored; while for $T < T^*$, the exothermic reaction dominates.

3.3.2 Chemical Heat Pump Reactions

Figure 3-7 illustrates the chemical heat pump mode of operation in which a dilute sulfuric acid solution is concentrated to 98% acid by using solar energy to evaporate water. The water vapor is condensed for storage, and the heat of condensation can be transferred to a load if it can be used at the condensation temperature or to the

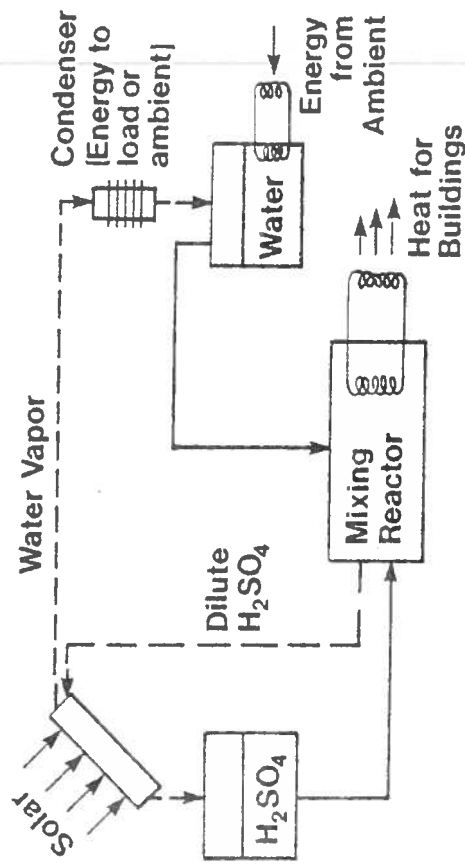
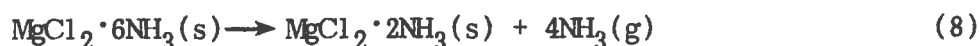

Figure 3-7. CHEMICAL HEAT PUMP STORAGE FOR SULFURIC ACID CONCENTRATION/DILUTION WITH THE CHARGING CYCLE REPRESENTED BY DASHED LINES (--) AND THE DISCHARGING CYCLE BY SOLID LINES (-)

environment if it cannot. When heat is demanded from storage, energy stored in the atmosphere can be used to evaporate the liquid water. Provided the temperatures of the water and acid solution are properly regulated, the water vapor will condense in the solution. Consequently, the heat of condensation as well as the heat of mixing can be released to the load, and energy is pumped from the environment. In principle, the total energy released during charging and discharging of storage exceeds that supplied by the sun because of the chemical heat pump capability, and if the energy can be used, the collector field size is reduced relative to a conventional storage system with potential savings in cost. By interchanging the load and environment positions in Figure 3-7, the chemical heat pump may be used for air conditioning as well, and a higher utilization of the solar system results.

Table 3-3 presents a number of reactions thought to be suitable for chemical heat pumping [23, 29-31]. The temperatures shown are the values typically considered although other values are possible depending on the operating pressure. The reactions of Table 3-2 generally could also be used in a chemical heat pump mode to recover the heat of condensation given off when the vapor is condensed, and the distinction between the modes is quite arbitrary.

Some of the gaseous components in Table 3-3, such as ammonia, are not readily liquified at close to atmospheric pressures and ambient temperatures. Due to the toxicity of the gases, high pressure operation of the system is undesirable since there is a high probability of gas release. For these compounds, it is generally convenient to employ a second solid to store the vapor since an appropriate solid lowers the vapor pressure of the gas at a given temperature. For example, if $\text{MgCl}_2 \cdot 6\text{NH}_3$ is supplied heat at about 120°C (248°F) as shown in Figure 3-8, it decomposes as:



To store the ammonia gas, it is reacted with $\text{CaCl}_2 \cdot 4\text{NH}_3$ at a temperature below 25°C (77°F):



The heat from this reaction is used for the load if possible or rejected to the atmosphere if not. When energy is to be released from storage, heat from the atmosphere is supplied to the $\text{CaCl}_2 \cdot 8\text{NH}_3$ at about 5°C (41°F) to drive off the ammonia by the reverse reaction to Equation 9. The ammonia is then absorbed by the $\text{MgCl}_2 \cdot 2\text{NH}_3$ in the reverse reaction to Equation 8 to liberate heat for the load at a temperature around 92°C (198°F). Different temperatures can be used for both storage and release of energy to meet different ambient temperatures provided they are consistent with the equilibrium requirements (Figure 3-9) and a differential pressure is provided between the two storage vessels to force the transfer of ammonia. Figure 3-10 illustrates the ammoniated salts system with operating conditions altered to provide air conditioning.

Metal hydrides have also been considered for operation in a manner similar to that described for the ammoniates. In these cases, hydrogen is driven between two metal

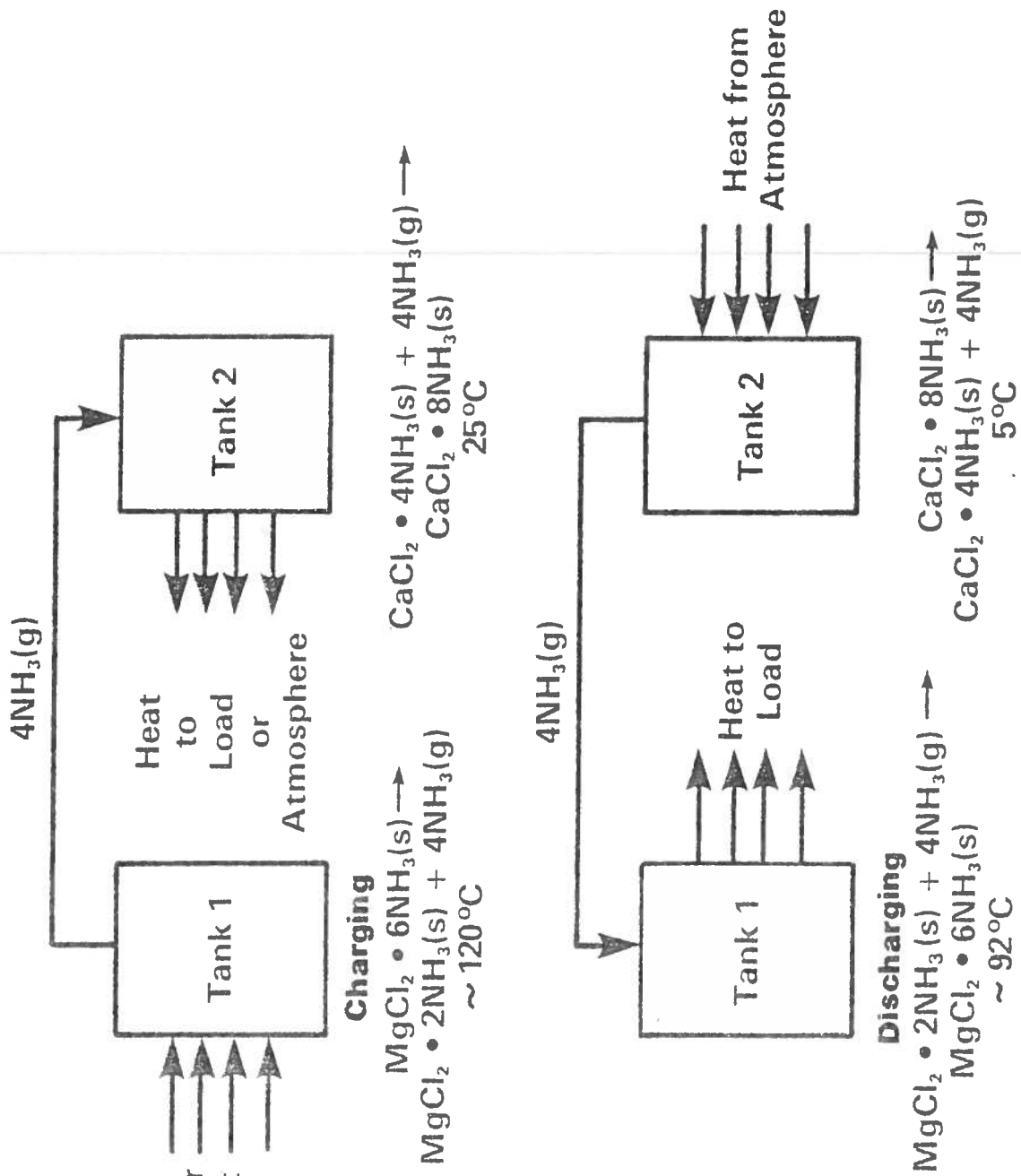

Figure 3-8. CHEMICAL HEAT PUMP STORAGE BY AMMONIATED SALT PAIRS FOR HEATING APPLICATIONS WITH THE UPPER DIAGRAM FOR CHARGING STORAGE AND THE LOWER FOR DISCHARGING

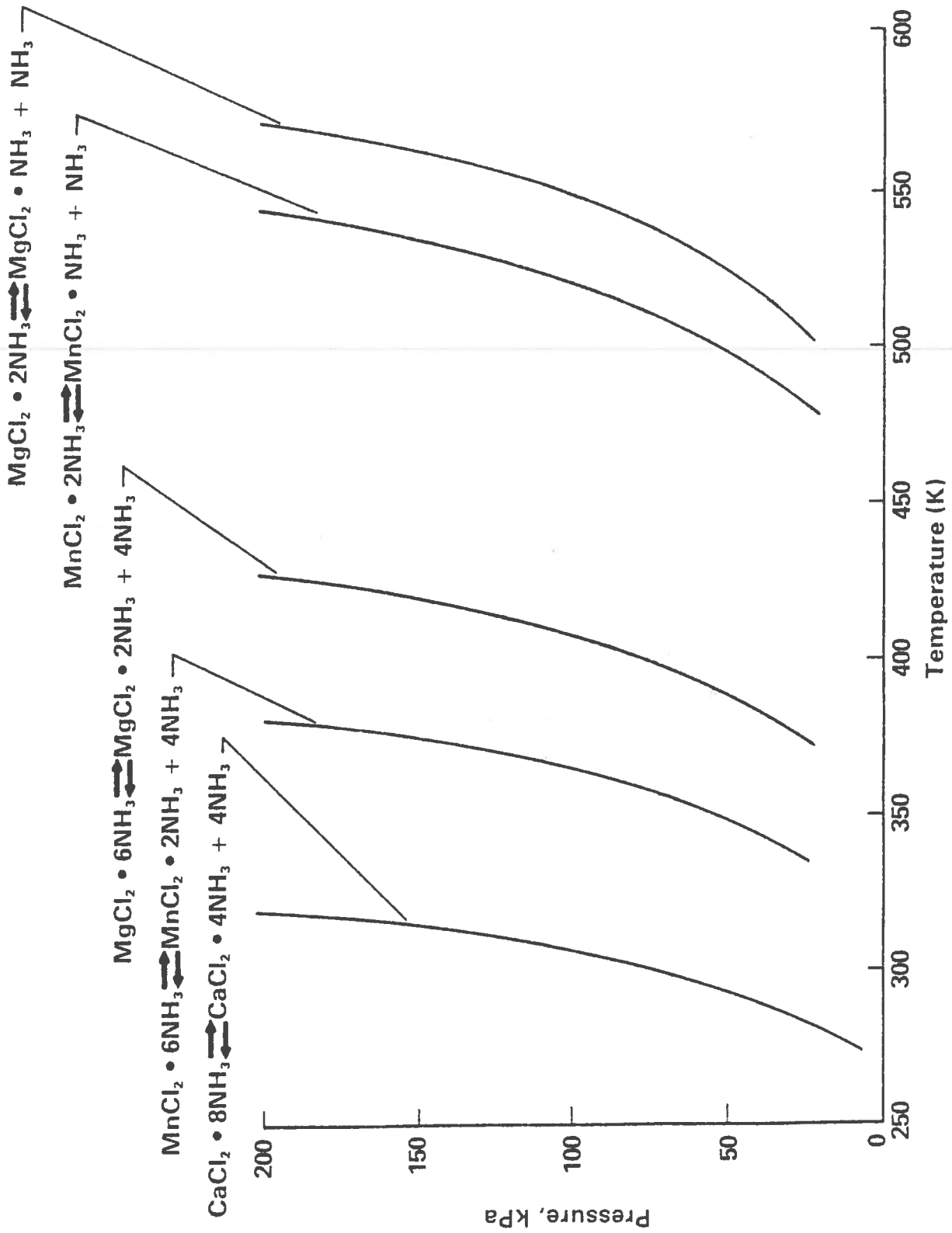

Figure 3-9. EQUILIBRIUM PRESSURES AS A FUNCTION OF TEMPERATURE FOR A VARIETY OF AMMONIATED SALTS [31]

Table 3-3

CHEMICAL HEAT PUMP STORAGE REACTIONS

Reaction	Temp., K
<u>Ammoniated Salt Pairs</u>	
$\text{CaCl}_2 \cdot 8\text{NH}_3(\text{s}) \rightleftharpoons \text{CaCl}_2 \cdot 4\text{NH}_3(\text{s}) + 4\text{NH}_3(\text{g})$	305
$\text{NH}_4\text{Cl} \cdot 3\text{NH}_3(\text{l}) \rightleftharpoons \text{NH}_4\text{Cl}(\text{s}) + 3\text{NH}_3(\text{g})$	320
$\text{MnCl}_2 \cdot 6\text{NH}_3(\text{s}) \rightleftharpoons \text{MnCl}_2 \cdot 2\text{NH}_3(\text{s}) + 4\text{NH}_3(\text{g})$	364
$\text{MgCl}_2 \cdot 6\text{NH}_3(\text{s}) \rightleftharpoons \text{MgCl}_2 \cdot 2\text{NH}_3(\text{s}) + 4\text{NH}_3(\text{g})$	408
$\text{MnCl}_2 \cdot 2\text{NH}_3(\text{s}) \rightleftharpoons \text{MnCl}_2 \cdot \text{NH}_3(\text{s}) + \text{NH}_3(\text{g})$	521
$\text{MgCl}_2 \cdot 2\text{NH}_3(\text{s}) \rightleftharpoons \text{MgCl}_2 \cdot \text{NH}_3(\text{s}) + \text{NH}_3(\text{g})$	550
<u>Hydrated Salts</u>	
$\text{MgCl}_2 \cdot 4\text{H}_2\text{O}(\text{s}) \rightleftharpoons \text{MgCl}_2 \cdot 2\text{H}_2\text{O}(\text{s}) + 2\text{H}_2\text{O}(\text{g})$	380
<u>Concentration Dilution</u>	
$\text{H}_2\text{SO}_4 \cdot n\text{H}_2\text{O}(\text{l}) \rightleftharpoons \text{H}_2\text{SO}_4 \cdot (n-m)\text{H}_2\text{O}(\text{l}) + m\text{H}_2\text{O}(\text{g})$	600

compounds. However, the metals are usually expensive and small quantities of material are employed in a thermally driven heat pump without storage capacity. The system is not considered as a cost-effective storage device [22, 23] and it will therefore not be considered further. More details on the metal hydride heat pump system without storage are available in Reference [32].

3.3.3 Thermochemical Pipeline Reactions

Significant enthalpy changes also accompany a number of reactions involving one or more gaseous reactants which are not easily condensed. Since the energy storage density is low, these reactions are not considered as attractive as the preceding for thermal energy storage although some workers have proposed using massive underground caverns or compressing the reactants/products for storage of the gaseous materials. Most applications utilize the reaction products for transmitting thermal energy over long

distances in a thermochemical pipeline (chemical heat pipe) operation. The endothermic sulfur trioxide decomposition reaction, for example, is driven catalytically at the energy source (Figure 3-11) as [23, 33]:



This reaction occurs at about 900°C. The gaseous reaction products exchange heat with the reactants and are transmitted at lower temperatures to a remote load site where the reverse exothermic reaction proceeds catalytically, liberating energy at about 550°C:



The products of this reaction are sent back to the source to repeat the cycle. A number of reactions considered for thermochemical pipeline applications are listed in Table 3-4 along with their standard heats of reaction [23, 24, 34]. All of the tabulated reactions must be triggered catalytically to avoid the necessity of separating the materials prior to transit.

Table 3-4

THERMOCHEMICAL PIPELINE REACTIONS

Reaction	ΔH° , kJ	T*, K
$\text{CH}_3\text{OH}(\text{g}) \rightleftharpoons 2\text{H}_2(\text{g}) + \text{CO}(\text{g})$	90.18	420
$2\text{NH}_3(\text{g}) \rightleftharpoons \text{N}_2(\text{g}) + 3\text{H}_2(\text{g})$	92.26	466
$\text{C}_6\text{H}_{12}(\text{g}) \rightleftharpoons \text{C}_6\text{H}_6(\text{g}) + 3\text{H}_2(\text{g})$		568
$\text{CH}_4(\text{g}) + \text{H}_2\text{O}(\text{g}) \rightleftharpoons \text{CO}(\text{g}) + 3\text{H}_2(\text{g})$	206.2	960
$\text{CH}_4(\text{g}) + \text{CO}_2(\text{g}) \rightleftharpoons 2\text{CO}(\text{g}) + 2\text{H}_2(\text{g})$	247.4	960
$\text{SO}_3(\text{g}) \rightleftharpoons \text{SO}_2(\text{g}) + 1/2 \text{O}_2(\text{g})$	98.94	1040

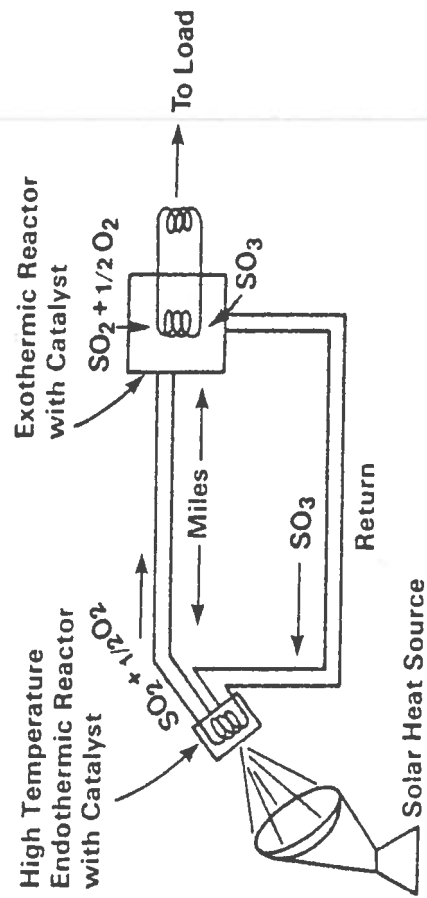

Figure 3-11. TRANSMISSION OF THERMAL ENERGY BY THE THERMOCHEMICAL PIPELINE SULFUR TRIOXIDE REACTION

SECTION 4.0

STORAGE VESSELS AND HEAT EXCHANGERS

It is obvious that the cost of the storage media and the container could constitute a significant portion of the energy related costs in Equation 1 and must be kept to a minimum. In addition, power related costs are frequently a substantial portion of the total system costs since heat exchangers and associated heat transfer equipment are generally very costly. Therefore, it is important to consider the design of low cost containers and heat exchangers as well as the selection of low cost materials for storage. In this section, attention is focused on a few of the concepts which are aimed at lowering the cost of heat exchange and containment. Most are in early development stages and require extensive effort to achieve that goal.

4.1 SENSIBLE HEAT SYSTEMS

In order to charge and discharge storage, it is necessary to circulate a heat transfer fluid between storage and either the energy source or the load. For liquid storage media, the storage fluid frequently can be used directly for heat transfer. If practical considerations such as freezing of the liquid prevent this, the storage liquid can be brought into thermal contact with an auxiliary heat transfer fluid via a conventional heat exchanger, although at additional expense. Alternately, a second fluid that is immiscible with the storage media can be bubbled through the storage container, and direct contact heat exchange thereby achieved between the heat transfer fluid and the storage media. Research is in progress on such a system for heating and cooling applications.

Solids are often desirable storage media according to the criteria outlined in the preceding section. Some of the solids for sensible heat or chemical reaction storage are in particulate form, and heat transfer through these materials is slow. In addition, the thermal conductivity of many of the solids considered for storage, including phase change materials, is low. To achieve useful heat transfer rates in a shell and tube heat exchanger, very high surface-to-volume ratios must generally be utilized. Even if the storage material costs are low, the heat exchanger costs usually make such a system uneconomical.

For solid sensible heat storage media, current practice is to put the heat transfer fluid in direct contact with the storage media. Numerous examples of such systems are available, but one of the more interesting is a dual media unit being considered for application to commercial power plants of 100 MW_e and larger size [17]. The concept originally employed a mixture of sand and granite to reduce the amount of more expensive organic oil, Caloria HT43, used in storage. However, the addition of solids facilitates temperature stratification in the storage vessel. For the device pictured in Figure 4-1, oil is circulated from the bottom of the storage vessel, through a heat exchanger to pick up heat, and back to the top of the storage tank. A fairly sharp temperature transition or thermocline will occur naturally between the hot and cold regions in the storage bed, and this thermocline will move downward through the bed

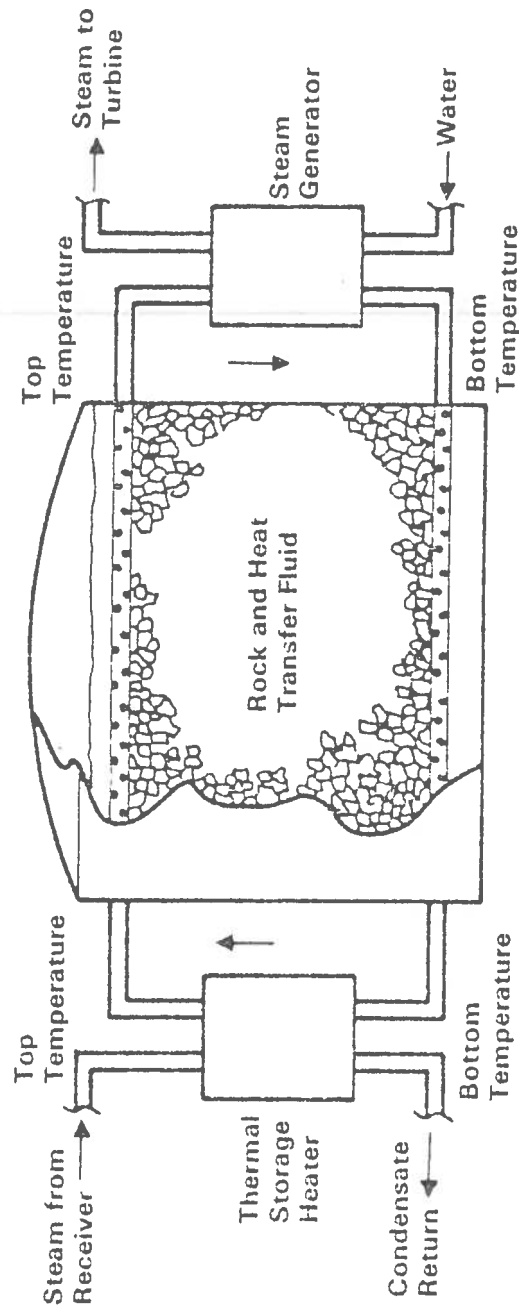

Figure 4-1. DUAL MEDIUM THERMAL STORAGE CONCEPT [17]

during charging. If the oil flow direction is reversed during extraction of heat, the thermocline will move upward through the bed. A constant discharge temperature is produced from storage as a result of this temperature stratification.

An analyses of the dual medium thermal storage unit has been developed to aid in engineering design [17]. Assuming the system can be modeled in terms of unidimensional, unsteady flow conditions the temperature of the oil can be predicted from the energy balance:

$$f \rho_L c_{pL} \frac{\partial T_L}{\partial t} + f \rho_L c_{pL} v_L \frac{\partial T_L}{\partial x} = - h (A/V) (T_L - T_S) \quad (12)$$

while the solid temperature can be predicted from the relation:

$$(1 - f) \rho_S c_{pS} \frac{\partial T_S}{\partial t} = h (A/V) (T_L - T_S) \quad (13)$$

f is the packed bed void fraction by volume, ρ_L the liquid density, ρ_S the solid density, c_{pL} the liquid specific heat, c_{pS} the solid specific heat, v_L the actual fluid velocity, h the heat transfer coefficient between the liquid and solid, A/V the area/volume ratio for heat transfer, T_L the fluid temperature, T_S the solid temperature, t the time, and x the axial distance down the tank. For constant physical properties, velocity, and boundary conditions, the Shumann-Hausen analytical solution can be used to solve these equations. A variable mesh numerical integration method has also been developed in Reference [17] to allow variation of properties with temperature and velocity and permit the use of arbitrary boundary and initial conditions.

Figure 4-2 and 4-3 show the numerically calculated and the observed thermocline for discharging and charging of the storage unit respectively. The surface-to-volume ratio, A/V , was adjusted in the model until the predicted and actual thermocline slopes matched at a value of about 40 ft^{-1} . It was also necessary to increase the solid heat capacity above the actual value for the calculated thermocline velocity to match the observed value. Based on these adjusted parameters, temperature histories were calculated at various locations in the bed for two charge-discharge cycles. The results are presented in Figure 4-4 along with the pilot plant data. Due to the nature of the thermocline, an essentially constant outlet temperature is provided by the pilot plant unit until it is almost completely charged or discharged.

Inexpensive containment of liquid sensible heat storage media is a major challenge in reducing system cost. For high-temperature thermal storage in water or other liquids with significant vapor pressures at the storage conditions, a low-cost pressure vessel is required. A vessel made of inexpensive cast iron blocks held together by axial steel tendons as shown in Figure 4-5 offers one solution. Underground solution caverns created in salt domes may be an economical way to contain high pressure water or other liquid storage media (Figure 4-6).

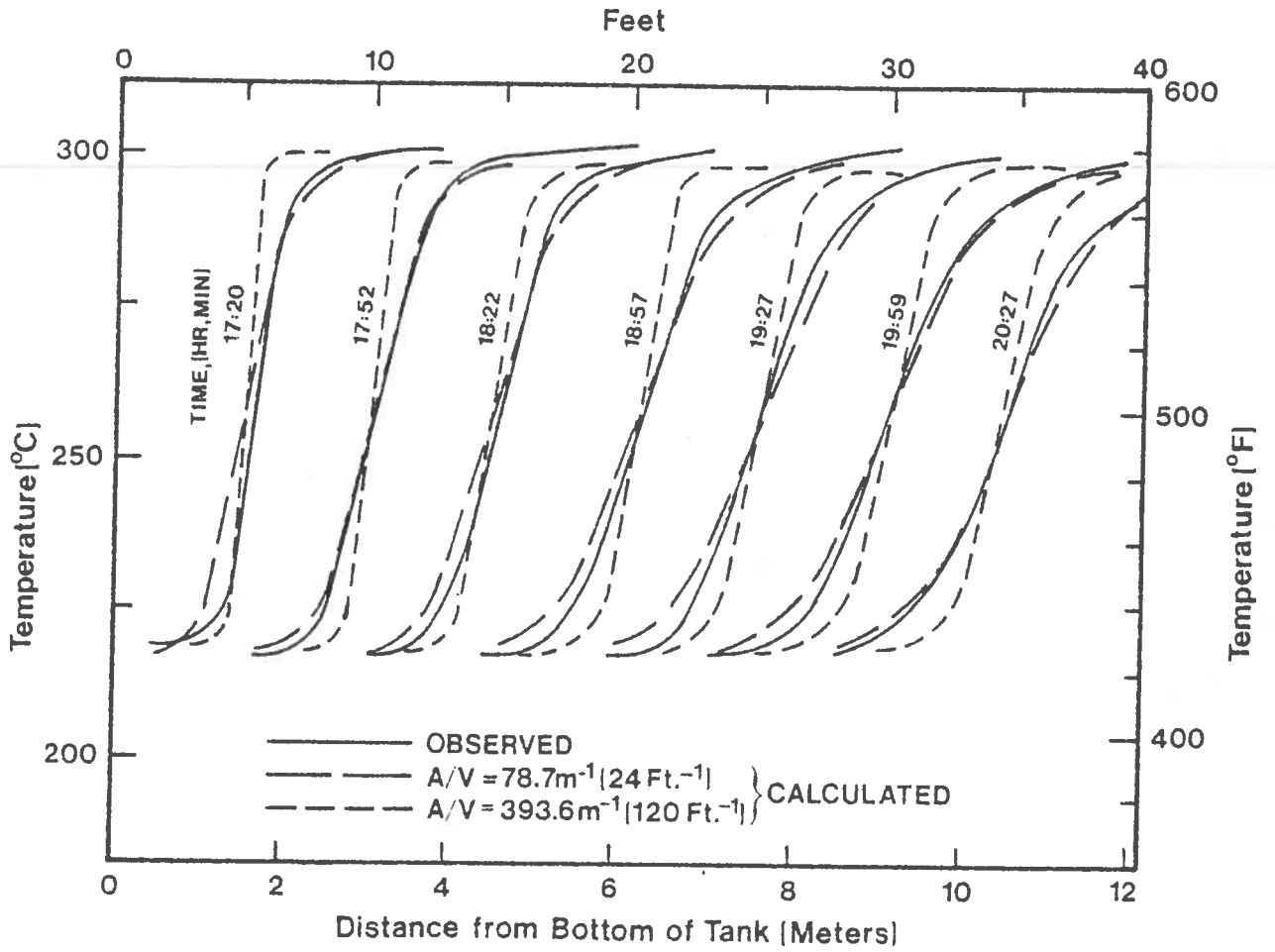

Figure 4-2. OBSERVED AND CALCULATED THERMOCLINES AT VARIOUS TIMES DURING STORAGE DISCHARGING [17]

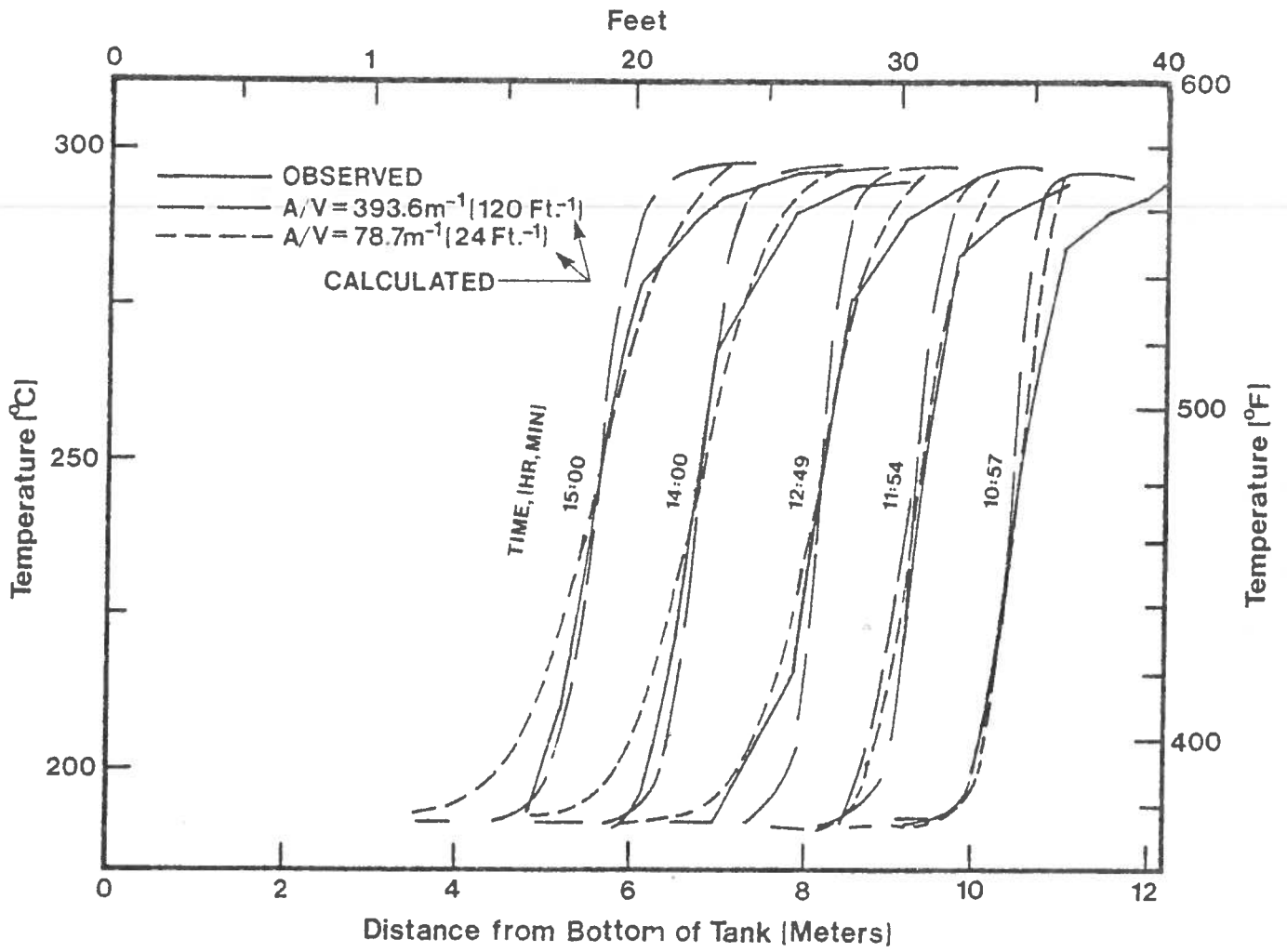

Figure 4-3. OBSERVED AND CALCULATED THERMOCLINES AT VARIOUS TIMES DURING STORAGE CHARGING [17]

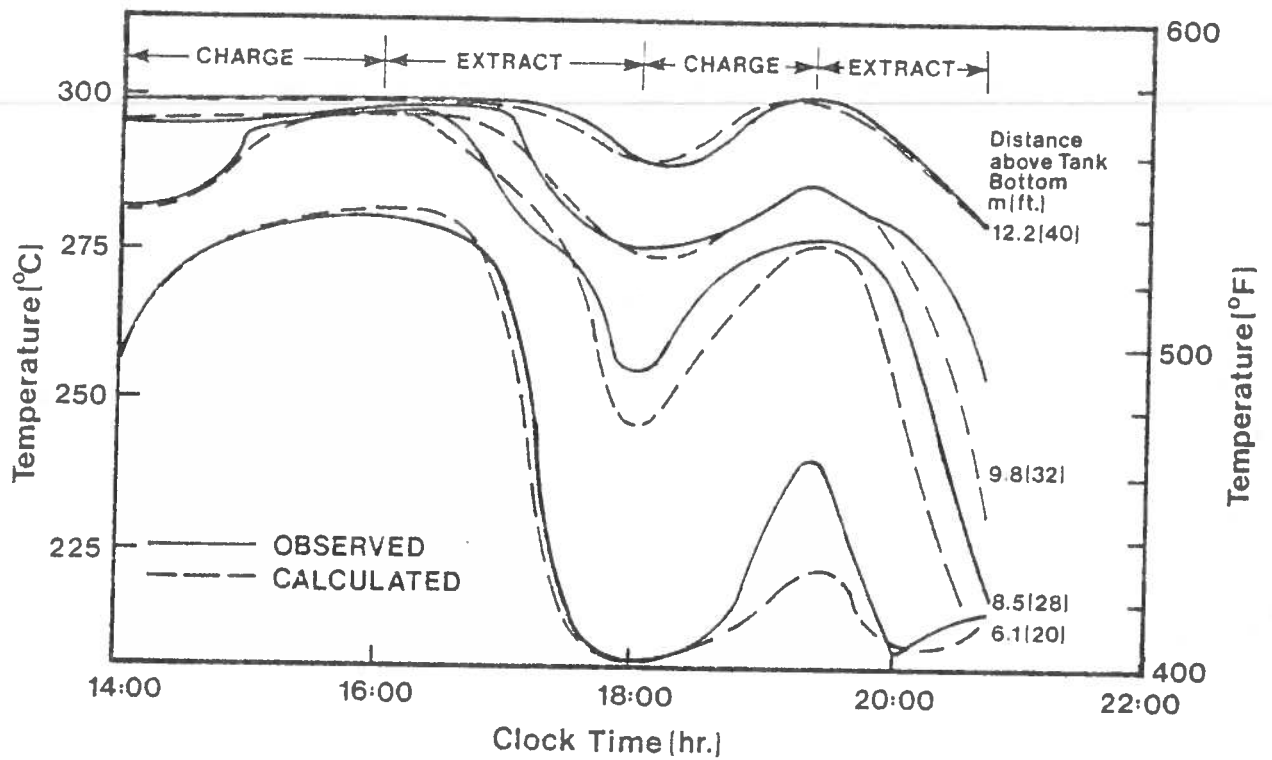

Figure 4-4. OBSERVED AND CALCULATED BED TEMPERATURE PROFILES AT VARIOUS BED LOCATIONS DURING TWO STORAGE CHARGING AND DISCHARGING CYCLES [17]

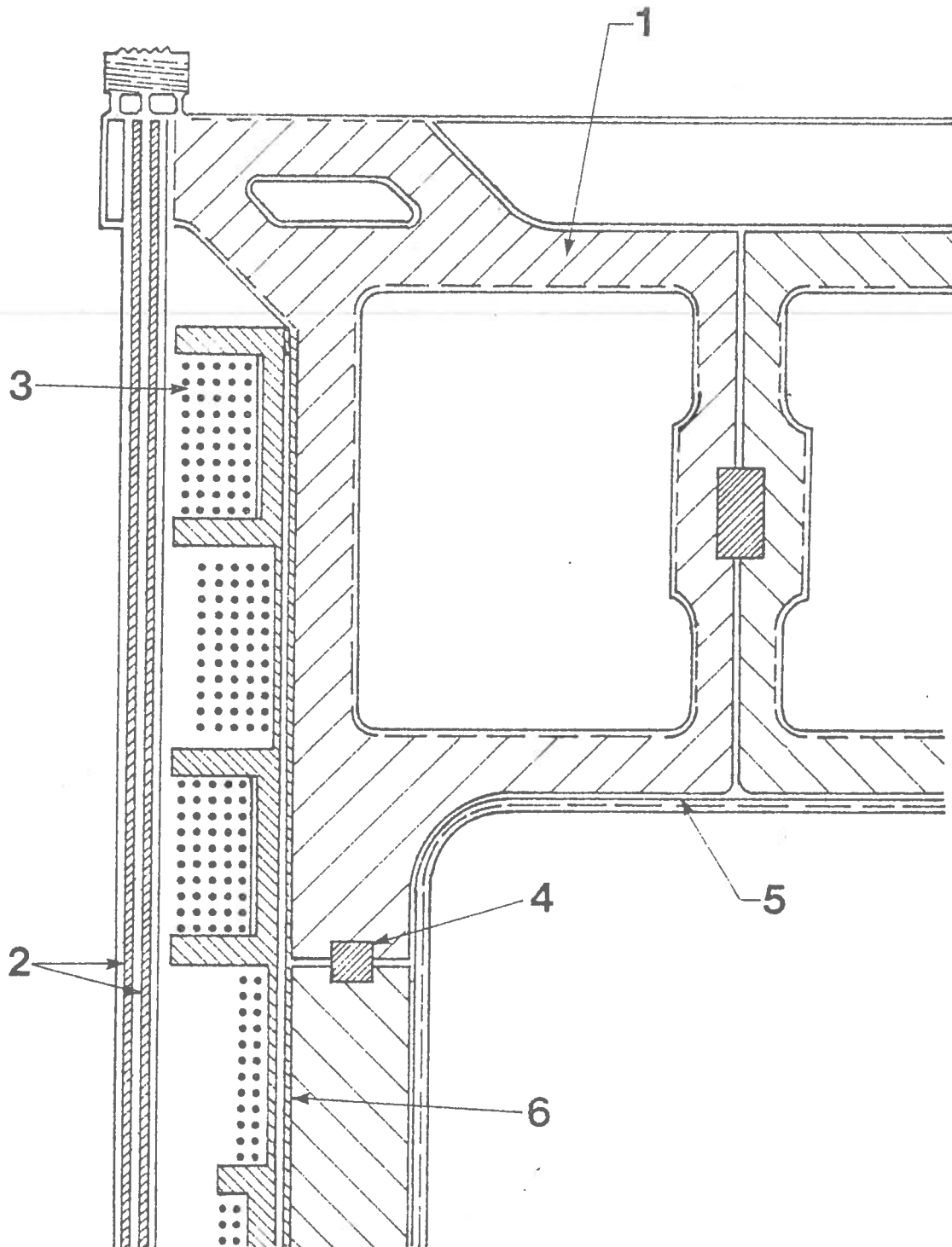

Figure 4-5. PRESTRESSED CAST IRON VESSEL FOR PRESSURIZED WATER STORAGE: 1. UPPER COVER; 2. AXIAL TENDONS; 3. TANGENTIAL TENDONS; 4. WEDGE; 5. LINER, AND 6. THERMAL INSULATION [35]

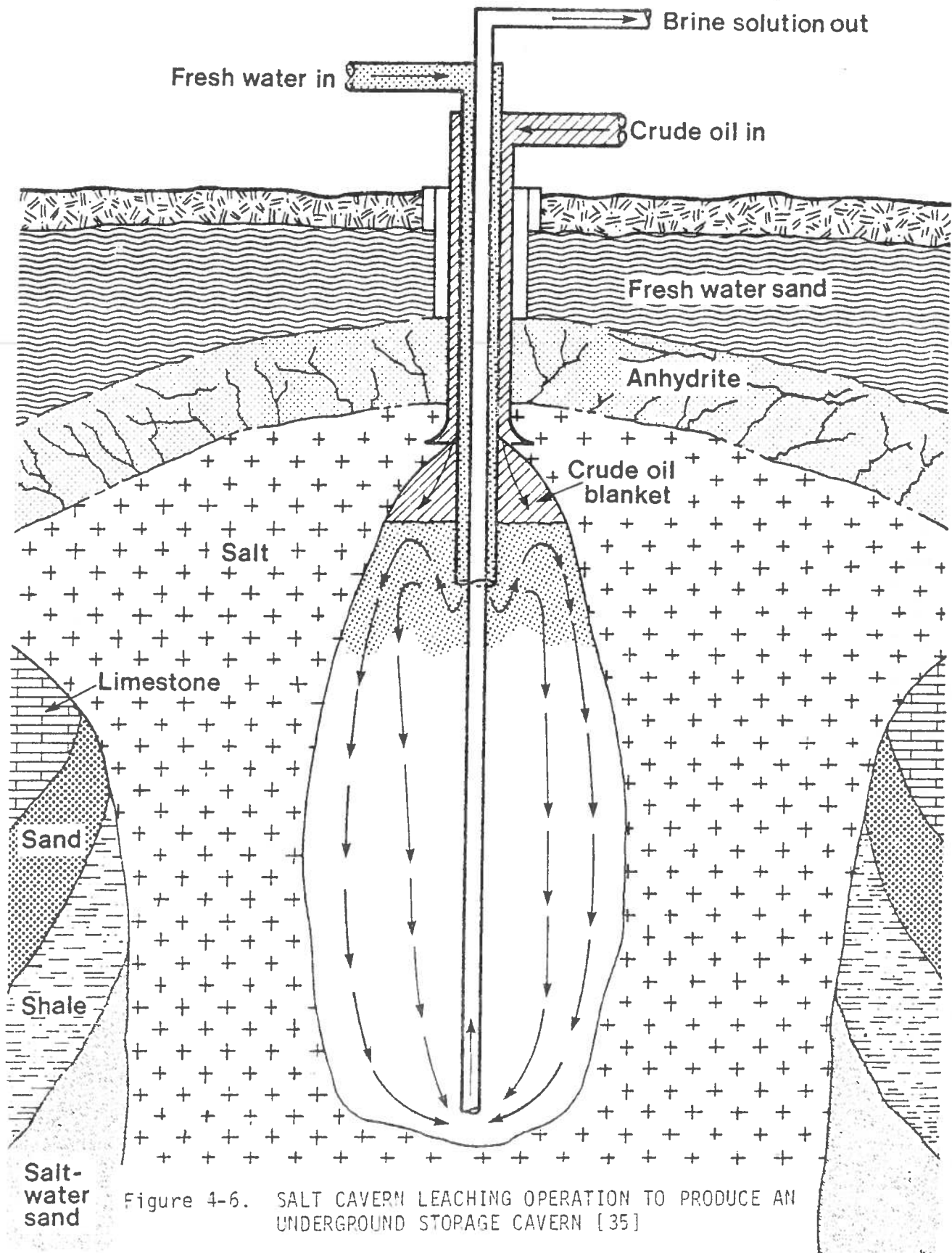

Figure 4-6. SALT CAVERN LEACHING OPERATION TO PRODUCE AN UNDERGROUND STORAGE CAVERN [35]

For long-term energy storage an inexpensive container is essential. Perhaps the most promising prospect is using a confined underground aquifer for storing water at lower temperatures. Aquifers are natural geological formations which contain and conduct water and are abundant in many parts of the world at depths from a few meters to several kilometers. Confined aquifers are surrounded by essentially impermeable formations and contain water under pressure. The flow rate of water through the aquifer is low enough that long duration storage of hot or chilled water looks feasible. Both the storage medium and its containment are provided by the aquifer, and the system costs are limited to drilling the well and outfitting it with heat exchanger equipment, pumps, and associated piping. At this time, the use of aquifers for storage is in its early development stages. More work must still be done to establish their technical, environmental, and economic feasibility, particularly when integrated into a solar system.

4.2 LATENT HEAT SYSTEMS

Heat transfer in latent heat storage materials is complicated by the phase change that occurs during storage or release of energy. During extraction of energy from storage, the liquid freezes on the heat transfer surfaces and an immobile layer of solid material continually grows as it gives up the heat-of-fusion. The layer of solid material often has a low thermal conductivity, and as it grows, heat transfer is impeded. In most operational latent heat storage devices, heat transfer to the load or energy source is through the container vessel walls. In order to provide adequate heat transfer through the frozen material, a high surface area to volume ratio is required for the combined container-heat exchanger. As mentioned in Section 3.0, the cost of such units can be substantial. Up to 50% or more extra volume must be provided to allow passage of a heat transfer fluid, and a good deal of the volume advantage offered by latent heat storage is sacrificed. Volume changes during the phase change can further complicate system design and add to system costs. Plastic containers show some promise for lower cost containment heat transfer for low-temperature home heating use with salt hydrates. Containers that can withstand the corrosiveness of high-temperature latent heat storage salts are far more costly.

One way to lower the cost of heat exchange is to eliminate the need for containers between the latent heat material and the heat transfer fluid. A direct contact low-temperature latent heat storage unit is illustrated in Figure 4-7. This device uses a heat transfer fluid which is immiscible in the storage medium and lower in density. The fluid enters the bottom of the storage unit and rises through the latent heat material, transferring heat and stirring the storage media as it moves. The heat transfer fluid coalesces in a pool at the top of the storage vessel and is then pumped back to the energy source or load prior to returning to the bottom of the storage vessel. In order for the heat transfer fluid to coalesce properly, the viscosity apparently must be below 4.5 cp for the salts used for storage [36]. This requirement restricts the choice of heat transfer fluids. It is also critical that the latent heat material freeze to a slurry and not into a solid block if heat transfer is to be made possible. A similar high-temperature system using fluoride salts for storage and liquid lead for heat transfer has been proposed [37]. Considerable work must still be undertaken to demonstrate the merits of this approach.

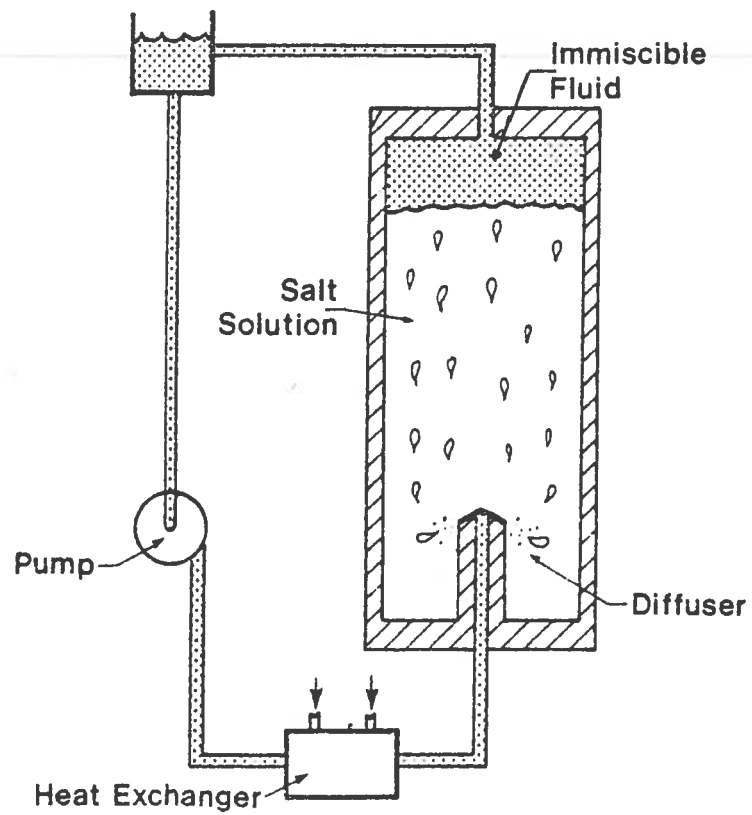

Figure 4-7. DIRECT CONTACT SYSTEM FOR HEAT TRANSFER BETWEEN THE LATENT HEAT STORAGE MEDIUM AND AN IMMISCIBLE FLUID [36]

Another approach to direct contact heat transfer in latent heat storage media relies on forming a pebble-like storage material. A heat transfer fluid can then be passed directly through a packed bed of the material. For instance, if crystalline polymer is crosslinked in a controlled manner either by radiation or by chemicals, the amorphous regions will crosslink more readily than the crystalline areas. The material now releases its heat-of-fusion upon being raised above the crystalline melting point even though it still remains in a solid rubbery state. High density polyethylene pellets have been chemically crosslinked in this fashion and the product retains about 98% of the initially high heat-of-fusion of the polymer. The crosslinked polymer melts between temperatures of 120°C and 140°C. More importantly, the crosslinked pellets will not fuse after releasing their enthalpy of melting, and a packed bed of the material can be formed [38]. Alternatively, materials such as paraffin wax can be encapsulated for use in a similar storage configuration [39]. Both of these materials tend to be more expensive than conventional latent heat storage substances but a substantial savings in the cost of the heat exchange system is possible. Therefore, the final system cost is potentially lower.

4.3 REVERSIBLE REACTION SYSTEMS

Storage of solar energy in reversible chemical reactions is in the early stages of concept development and the problem of providing an inexpensive means of heat transfer has not been adequately dealt with. As a class, gas-solid reactions show promise for chemical storage but possess the inherent problem of poor heat transfer through the solids. Many of the current devices under development for low-temperature storage of energy in solid reaction materials for home heating and cooling use shell and tube type heat exchangers for both containment and heat transfer in a manner similar to heat-of-fusion systems. The storage materials are placed on the shell side, and due to the low conductivity of the packed bed, the tubes have to be placed close together to obtain satisfactory heat addition and withdrawal rates. The cost of these heat exchanger containers is high and is usually far more than the price of many of the storage materials.

In an alternate concept, the solids are placed permanently in the solar collector itself [40]. Radiation is directly absorbed by the container for the solids, and water is released from a $\text{MgCl}_2 \cdot 4\text{H}_2\text{O}$ reactant by the endothermic forward reaction:

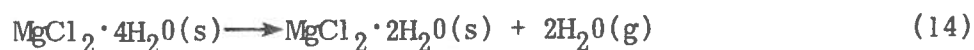

For a solar collector able to supply heat at 120°C (250°F), this decomposition reaction occurs at point D on the equilibrium pressure-temperature diagram in Figure 4-8. The water is condensed in a separate vessel at a slightly lower pressure (to promote water vapor movement) and at a temperature slightly above the home heating load value, point C in Figure 4-8. If the load demands heat, this enthalpy of condensation is given off to the load; otherwise, it must be rejected to the atmosphere.

When the load demands energy from storage, the system is run in a chemical heat pump mode. Energy from the atmosphere is used to evaporate the water (point A in Figure 4-8), and the water vapor reacts with the salt in the collector according to the exothermic reverse reaction:

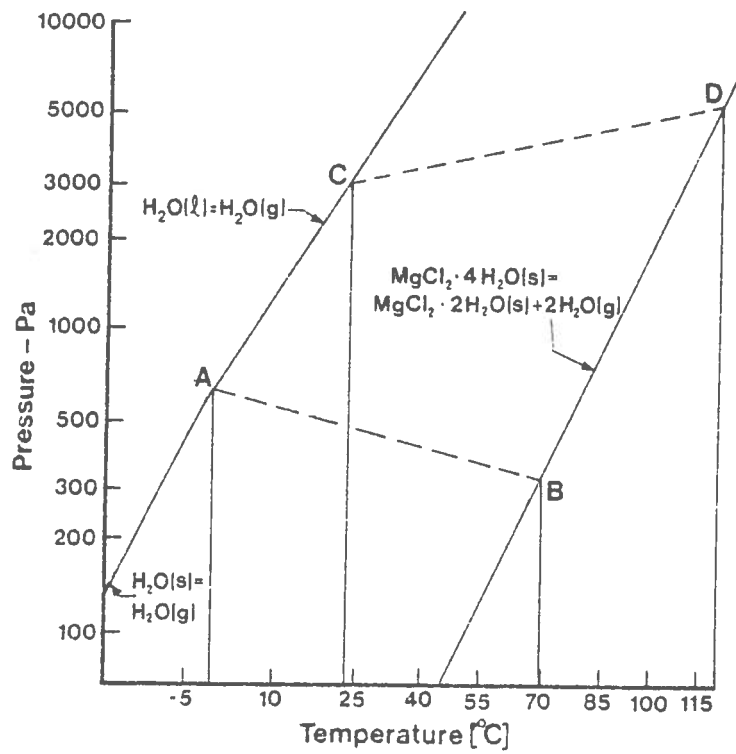

Figure 4-8. EQUILIBRIUM PRESSURE-TEMPERATURE DIAGRAM FOR HYDRATES OF MAGNESIUM CHLORIDE AND WATER [40]



This reaction occurs at point B on the equilibrium curve. The energy released by the reaction is sent to the load. Of course, this device may also be used for air conditioning by reversing the position of the load and environment while discharging storage. A pressure of about one kPa (.01 atm) is required to operate this system, and the device must be carefully sealed to insure long-term operation.

Some of the reactions discussed in Section 3.0 involve either just gases or gases and liquids for thermal energy transmission. A heat exchanger-reactor-receiver is being developed to handle these types of reactions and in particular, the $\text{SO}_3/\text{SO}_2/\text{O}_2$ chemical heat pipe reaction [41]. A diagram of the system is shown in Figure 4-9 with the details more clearly visible in Figure 4-10. SO_3 flows into the receiver cavity through a spiral counterflow ceramic heat exchanger that heats the SO_3 up to a temperature close to that in the reaction chamber. The SO_3 dissociates on the catalyst dispersed on the cavity walls while simultaneously absorbing solar energy to drive the endothermic reaction. The dissociated gas then exits through the counterflow spiral heat exchanger and releases its sensible heat to the inflowing SO_3 . By exchanging heat, the gases may be transmitted more efficiently at lower temperatures. This device is still in the early stages of development, and considerable work is still required to make it operational and establish its utility in a solar application.

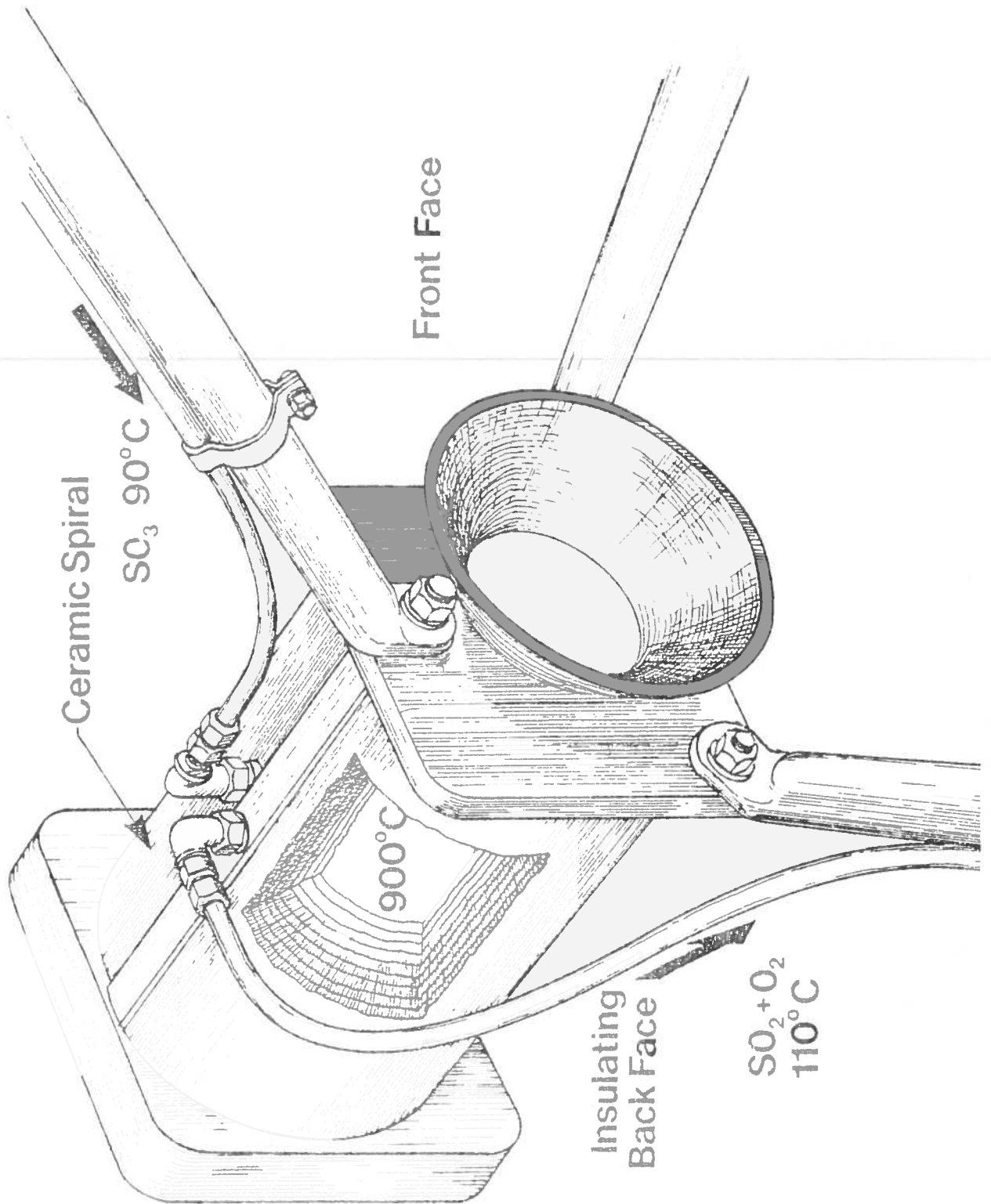

Figure 4-9. CAVITY CONVERTER-HEAT EXCHANGER FOR SO_3 DECOMPOSITION [41]

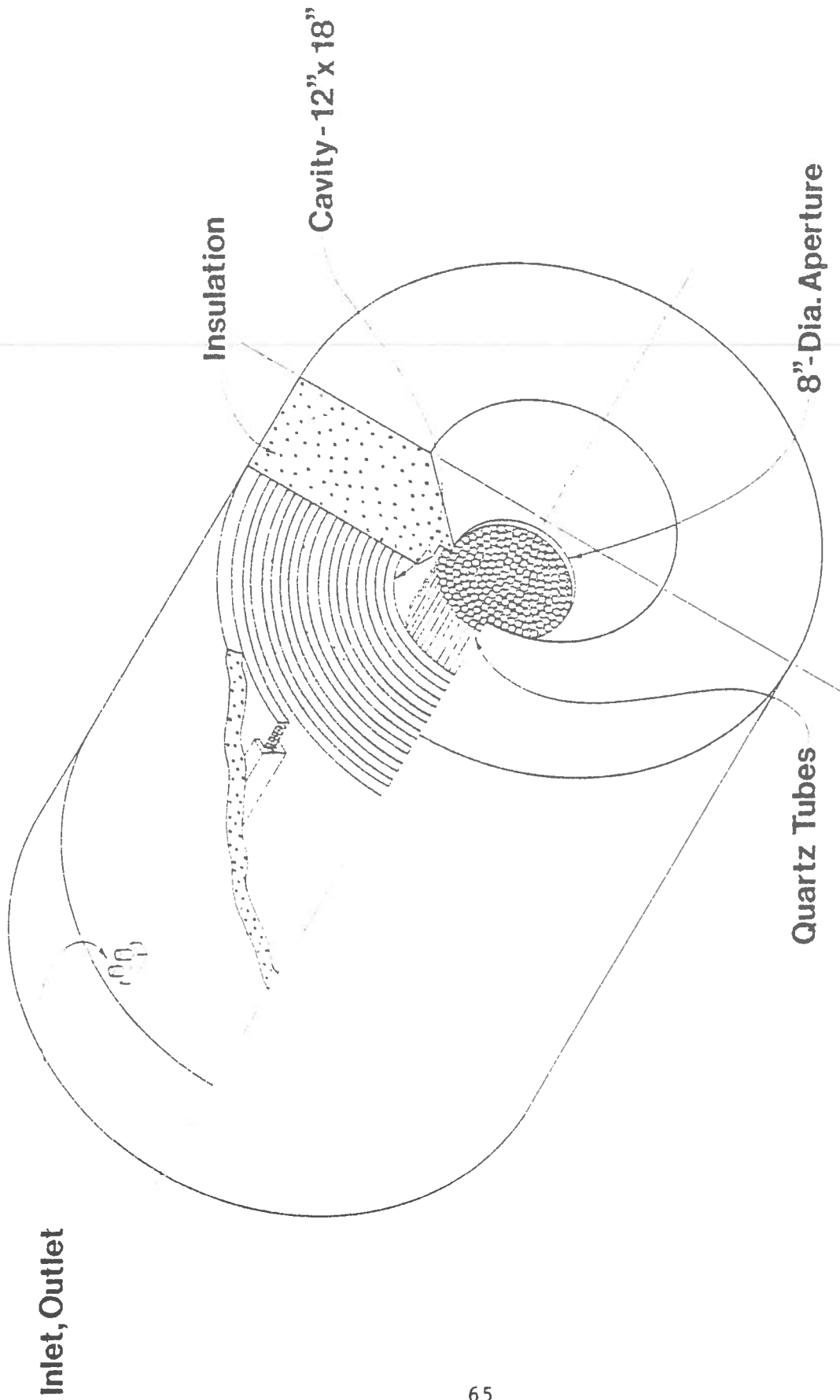

Figure 4-10. DETAILS OF CONVERTER-HEAT EXCHANGER CAVITY FOR SO₃ DECOMPOSITION [41]

SECTION 5.0

CHEMICAL STORAGE REQUIREMENTS

In this section some of the thermodynamic, kinetic, and heat exchange requirements of reversible chemical reactions will be discussed. Particular attention will be focused on the requirements and limitations of chemical reactions for efficient thermal storage. The aim of this analysis is to indicate which chemical reaction systems hold promise for solar storage and what important issues must be addressed to facilitate commercial implementation of this promising storage technology. The thermodynamic constraints on heat transfer for sensible, and latent heat systems will not be included since these issues have been addressed elsewhere [13].

5.1 EQUILIBRIUM CONSIDERATIONS

The free energy change for a reversible reaction ΔG can be expressed in terms of the equilibrium constant K as:

$$\Delta G = - RT \ln K \quad (16)$$

The free energy change can also be related to the enthalpy and entropy changes of the reaction by:

$$\Delta G = \Delta H - T \Delta S \quad (17)$$

If the equilibrium constant has a value of one, the free energy change is zero, and the reactants and products will be present in approximately equal quantities depending on the reaction stoichiometry. Thus, Equation 17 can be solved for an "average" or "turning" temperature T^* required to make $\Delta G = 0$:

$$T^* = \frac{\Delta H}{\Delta S} \quad (18)$$

Generally, ΔH and ΔS are approximated by their standard values as presented in Equation 7 to simplify the analysis.

A high energy storage density is very desirable in chemical storage, and a high enthalpy change ΔH is therefore important in Equation 18. Furthermore, to provide energy storage for a variety of solar applications, it is necessary that reactions exist for a range of temperatures. Examining Equation 18 reveals that to get appreciable enthalpy changes ΔH for low-temperature heating and cooling or industrial process heat applications, the entropy change ΔS must be large.

In approximate terms, a high entropy change is associated with a transition from a highly ordered state to a highly disordered state. A solid would provide the ordered structure,

particularly if it is crystalline, while a gas would be considered disordered. Therefore, reactions in which a solid (ordered structure) decomposes to form one or more gaseous compounds (disordered structure) seem to provide the high entropy change required to allow a high enthalpy change at lower temperatures.

Examination of Tables 3-2 and 3-3 reveals that the lower temperature reactions are essentially all gas-solid type reactions. Furthermore, this class of reactions spans a wide-scale of temperatures while gaseous and liquid reactions tend to occur mainly at higher temperatures. Since the enthalpy changes associated with gas-solid reactions are large and the products can be stored as liquids or solids, sizeable energy storage densities are possible as well. The decomposition products can also be readily separated to prevent back reaction during storage, and no elaborate separation step is required prior to storage. It is evident from these considerations that of the various reversible reactions, the gas-solid reactions as a class appear to provide the most promise for solar energy storage. However, their performance must be clearly demonstrated.

Another important consideration in the selection of a storage reaction is the manner in which the forward and reverse reactions are driven. For example, a general reversible dissociation reaction can be written as:



where k_f is the forward rate constant and k_r is that for the reverse reaction. If these components are all gaseous, the equilibrium expression for the reaction is:

$$\frac{[R][S]}{[A]} = \frac{k_f}{k_r} = K \quad (20)$$

To cause the endothermic forward reaction to proceed to an appreciable extent, the equilibrium constant should be much greater than one. Therefore, the forward rate constant k_f should be much greater than the reverse constant k_r . Either rate constant is generally given by an Arrhenius expression of the form,

$$k = k_0 e^{-E/RT} \quad (21)$$

where k_0 is the frequency factor (a constant), E is the activation energy of the reaction, R is the gas constant, and T is the absolute temperature. Since $E_f > E_r$, a high-temperature will favor the forward endothermic reaction. On equilibrium grounds, the free energy change must be negative, and the temperature T must be greater than the turning temperature T^* .

Once energy has been stored by the endothermic forward reaction, energy can be released by the exothermic reverse reaction. In this case, the equilibrium concentration of A must be much higher than that of R or S in Equation 20; the equilibrium constant K must be much less than one. By lowering the system temperature, k_f will decrease much

more rapidly than k_r . At a low enough temperature, their ratio, which is equal to the equilibrium constant, will be much less than one as desired. Thus, the system temperature must be less than the turning temperature T^* to yield the positive free energy change required for a K less than one.

The change in temperature necessary to shift the equilibrium conversion significantly for gaseous reactants may be several hundred K. For example, in Figure 5-1, the equilibrium fraction of SO_3 converted to SO_2 and O_2 is plotted against temperature for two pressures. To proceed from 90% of the SO_3 converted to SO_2 and O_2 at the receiver to 10% of the SO_3 converted to SO_2 and O_2 after energy release at one atmosphere pressure would require that the temperature be dropped from about 1200 K at the solar receiver to less than 800 K during release. As discussed in Section 2.0, such a large temperature drop could impose a significant penalty on collector operating efficiency and cost. In addition, the reverse reaction will proceed more slowly than the forward reaction, and a larger reactor will be needed to release the energy. Alternatively, if the pressure were increased significantly in the system during the energy release stage, the energy could be released at a temperature closer to the endothermic value. However, this will require a compressor in the storage loop with significant parasitic power requirements likely.

For a gas-solid reaction, substances A and R in Equation 19 are solids while S is a gas. In such cases, activities are used in Equation 20 in place of concentrations for the solids while the partial pressure of the gas is used in the same expression. Furthermore, the activities of the solids are approximately equal to one leading to the simple result:

$$K = p_{s,eq} \quad (22)$$

where p_s is the equilibrium pressure of the gas S. Therefore, as long as the pressure of the gas is less than $p_{s,eq}$, the endothermic forward reaction will proceed to completion while if the gas pressure is greater than $p_{s,eq}$, the exothermic reverse reaction will take place.

The equilibrium curves for gas-solid reactions involving magnesium oxide and calcium oxide are shown in Figure 5-2. For a water vapor pressure of one atmosphere, the calcium hydroxide will decompose if heated above 520°C since the equilibrium pressure is above one atmosphere. On the other hand, if the system is cooled below 520°C , any calcium oxide in the system will now hydrate since the equilibrium pressure is below one atmosphere. Thus, in principle, the direction of the reaction can be reversed with small changes in temperature.

Unfortunately, there may be some kinetic limitations to the use of gas-solid reactions with small temperature swings. The rate of reaction is influenced by variables such as the temperature, extent of reaction, and the difference between the equilibrium pressure and the system gas pressure. To rapidly react the gas with the solid in the exothermic reverse reaction of Equation 19, it may be necessary for the equilibrium pressure to be considerably below the system pressure. Thus, as noted from equilibrium plots such as Figure 5-2, it would be desirable to lower the solid temperature. However, lowering the temperature also lowers the rate constant decreasing the reaction rate. A compromise

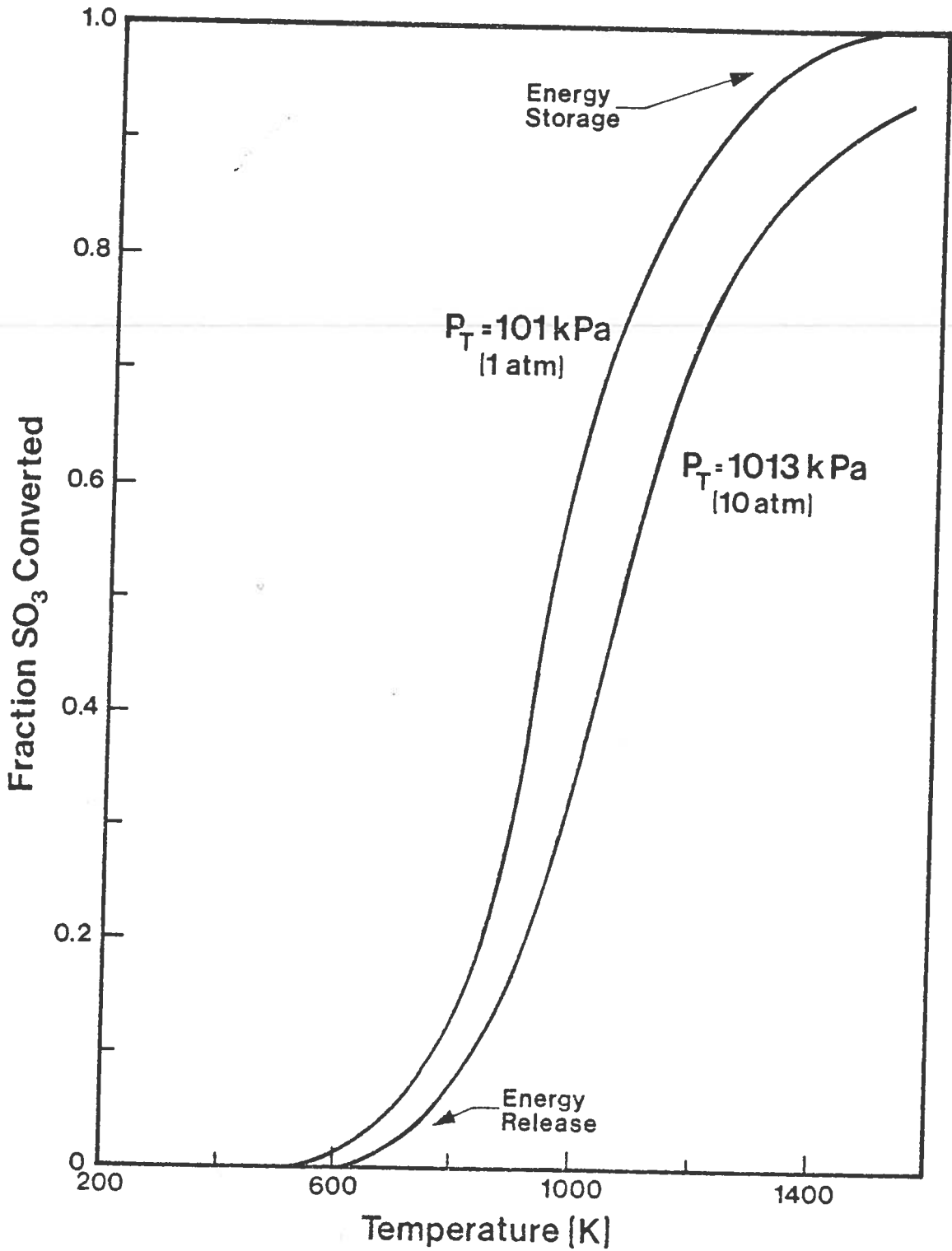

Figure 5-1. EQUILIBRIUM CONVERSION OF SO₃ AS A FUNCTION OF TEMPERATURE [23]

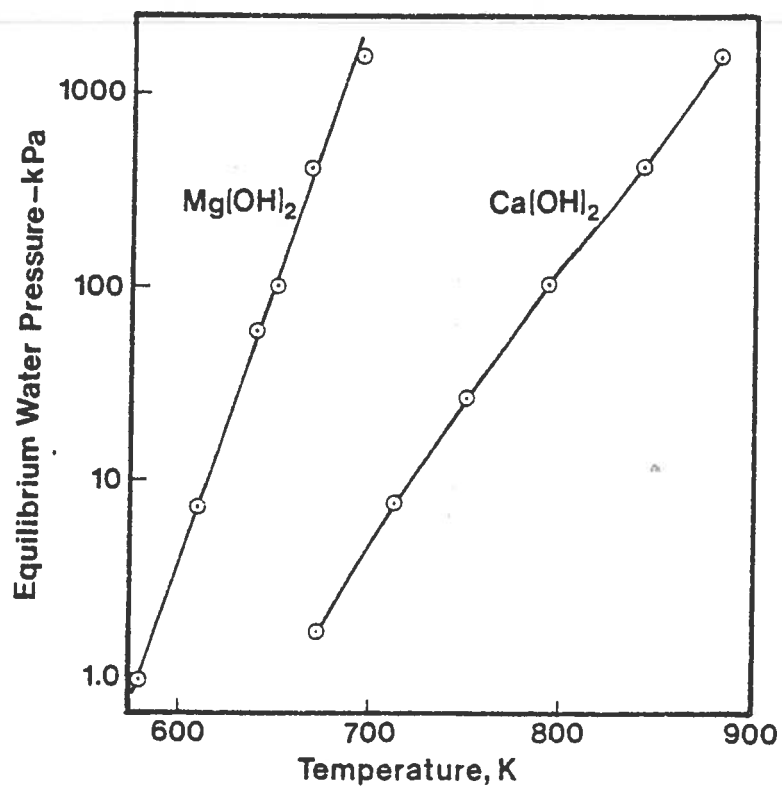

Figure 5-2. EQUILIBRIUM PRESSURE FOR HYDROXIDES AS A FUNCTION OF TEMPERATURE [27]

Reprinted by permission of the American Society of Heating, Refrigerating, and Air-Conditioning Engineers, Inc.

between these two extremes must be made. Diffusion of the gas through the solid can further complicate matters with the net result that the rate exhibited by some gas-solid reactions may become extremely low. More work is required to understand the exact nature of the reactions, quantify it, and determine its effect on reactor design and the temperature swings required.

One intriguing possibility can arise from the unusual equilibrium characteristics of the gas-solid reactions. Calcium hydroxide could be decomposed by a solar collector at a temperature of about 440°C (825°F) to produce water vapor with a pressure of about 0.07 atm. The water could then be condensed at 38°C (100°F) where the water vapor pressure is slightly below 0.07 atm. If a sizeable source of waste heat were available above 100°C (212°F), it could be used to produce steam at 100°C and one atmosphere pressure. The steam could then be reacted with the dehydrated calcium oxide to produce temperatures close to 520°C (968°F), a temperature above the original collector temperature.

5.2 ENERGY FROM STORAGE

In the analysis that follows, it is assumed that as much as possible of the energy from storage should be available at essentially the same temperature as generated by the collectors. Even if the temperature requirements of the load are well below the collector temperature over a large portion of the process, the size of the heat exchangers and other components will be minimized for the large temperature difference available. If the storage unit produces a significantly smaller temperature difference, than a larger heat exchanger is needed to accommodate the storage unit and an additional cost penalty is accrued against storage. In addition, subsequent process units may have to be designed to handle lower temperatures than are optimum. It is further assumed that energy produced at a temperature below that of the collector during the charging of storage is not very useful, and it is far more desirable to release energy from storage only upon demand. For various applications, it may be desirable to relax some or all of these restrictions with some simplifications in the storage design requirements, but a detailed system design is necessary for each application to identify the tradeoffs. Such studies are beyond the scope of this report.

For the purposes of this discussion, the reversible reaction

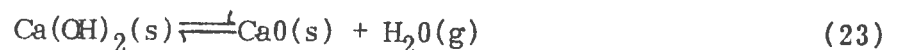

is employed as an example since good thermodynamic data is available and the reaction has significant potential for high-temperature thermal storage. Complete reaction is assumed to occur. The transition



is used to allow storage of the water. Arbitrary operating conditions are employed for these examples. Other conditions could be used with little change in the conclusions. A

continuous operation is assumed for the different operating schemes discussed to illustrate the effect of the mode of storage operation on the energy delivery temperature and the storage characteristics calculated are therefore based on enthalpy changes. For batch operations, the internal energy change should be quite similar, and the general conclusions will still apply.

The first operational mode is based on storing all materials at high temperatures. The storage and release reactors are assumed to operate at a water vapor pressure of one atmosphere, and water is condensed for storage. Hydrated lime, Ca(OH)_2 , is contained at 520°C (968°F) until it can be dehydrated with solar thermal energy. The CaO produced by reaction 23 is also stored at 520°C while the water must be cooled to 100°C (212°F) and condensed as shown in Figure 5-3. To release the stored energy, the 100°C water and 520°C CaO are mixed in a suitable reactor to produce heat.

Figure 5-4 presents the energy released in MJ per kg of Ca(OH)_2 required during both charging and discharging of storage as a function of temperature for the operational scheme discussed. The energy released at temperatures below 520°C is that necessary to cool down and condense the water during charging of storage while the energy released at 520°C is due to the hydration reaction during discharge. The COP (coefficient of performance) in Figure 5-4 is defined as the ratio of the total energy delivered from storage to the solar energy input, and since the total amount of solar energy needed to charge the storage system at 520°C is equal to the total energy output of 1.45 MJ/kg, the maximum COP is equal to one. However, only 48% of that energy output is released during the discharge of storage at the input temperature of 520°C . The other 52% of the solar energy into the system is released at temperatures below 520°C while the system is being charged. In fact, about 38% of the total solar energy input is available at 100°C during the charging phase. One should note that the effective specific heat shown in Figure 5-4 is simply the total energy storage capacity divided by the total required temperature swing to produce it. The value shown is less than sensible heat storage in liquid water although the temperature distribution is certainly far different.

The energy "wasted" in the previous case is the result of cooling the water vapor from 520°C to 100°C and condensing it at 100°C . If the temperature of this energy is too low to be useful at any other location in the process, the energy must be simply discharged to the environment. The value of this energy is not as high as the input energy even if used, particularly since a high-temperature collector was required to capture it. In some cases, it may be possible to use waste heat available at slightly above 100°C to improve the energy distribution. This energy could be used to evaporate the water during discharge of storage, and the water vapor at 100°C can be added to the CaO stored at 520°C . Thus, heat is pumped from a low-temperature waste stream in the process to the high-temperature point where stored energy is released as shown in Figure 5-5.

A diagram of the amount of energy released from storage is plotted against its release temperature in Figure 5-6 for the chemical heat pump system described. Again, the energy released below 520°C is that associated with cooling down and condensing the water vapor during the charging of storage. Although the total energy input is again equal to the total energy output, the solar energy input is only equivalent to the energy

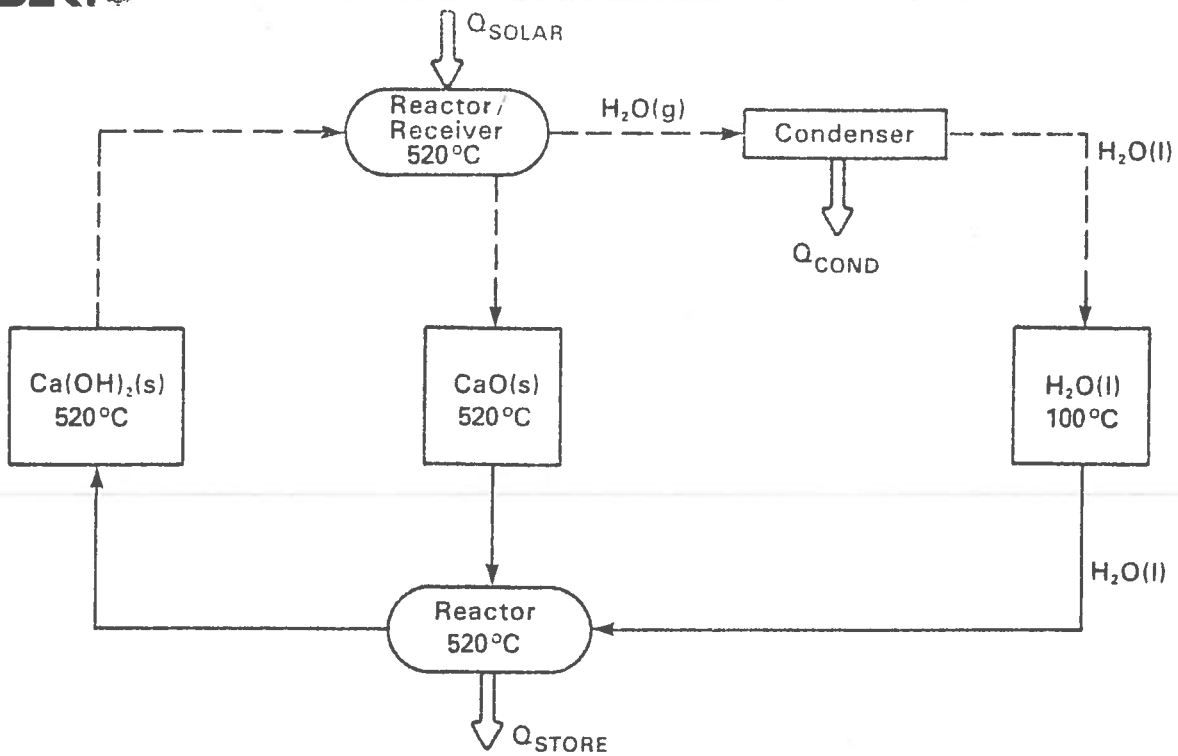

Figure 5-3. THERMAL ENERGY STORAGE SYSTEM BASED ON CALCIUM OXIDE/HYDROXIDE WITH MATERIALS STORED AT HIGH TEMPERATURES. THE CHARGING CYCLE IS SHOWN BY DASHED LINES AND THE DISCHARGING CYCLE IS SHOWN BY SOLID LINES

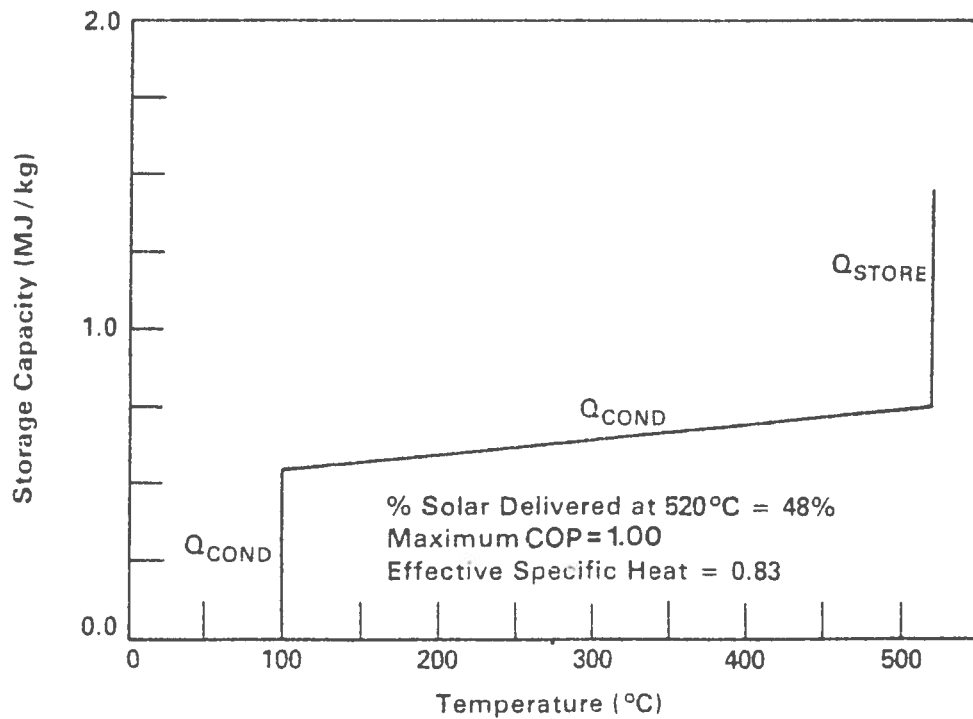

Figure 5-4. ENERGY RELEASED AS A FUNCTION OF TEMPERATURE FOR CALCIUM OXIDE/HYDROXIDE WITH MATERIALS STORED AT HIGH TEMPERATURES

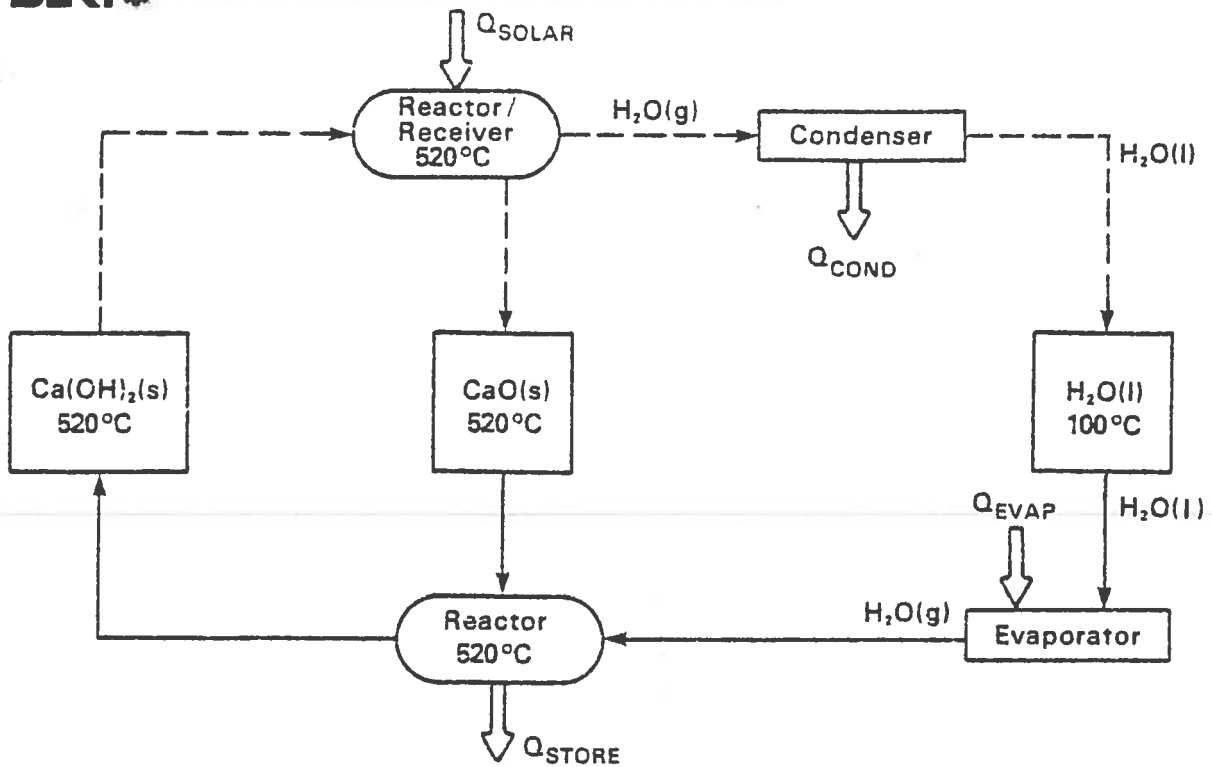

Figure 5-5. THERMAL ENERGY STORAGE SYSTEM BASED ON CALCIUM OXIDE/HYDROXIDE WITH MATERIALS STORED AT HIGH TEMPERATURES AND WITH WASTE HEAT USED TO EVAPORATE WATER IN A CHEMICAL HEAT PUMP MODE. THE CHARGING CYCLE IS SHOWN BY DASHED LINES AND THE DISCHARGING CYCLE IS SHOWN BY SOLID LINES

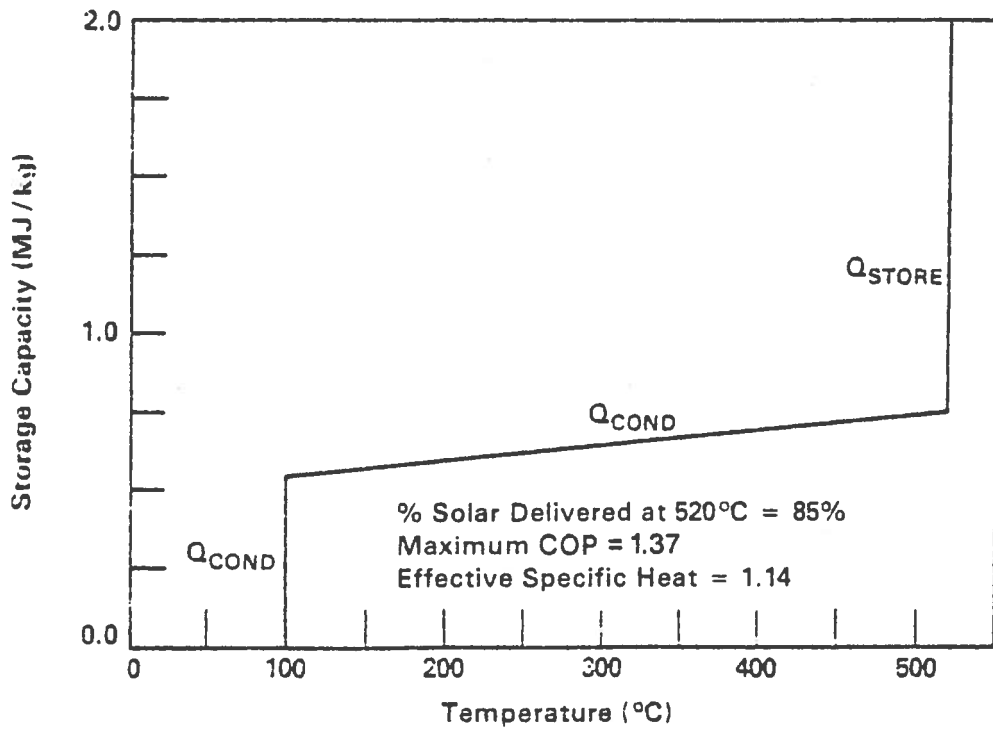
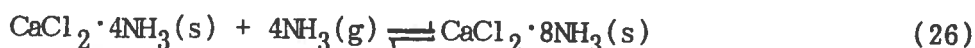
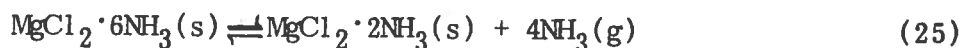

Figure 5-6. ENERGY RELEASED AS A FUNCTION OF TEMPERATURE FOR THE CHEMICAL HEAT PUMP SYSTEM SHOWN IN FIGURE 5-5

output shown above 100°C since the waste stream energy is used to evaporate the water at 100°C. Thus, the coefficient of performance is 1.37. However, only 85% of the solar energy used to charge storage is delivered at 520°C. Overall, the total energy released yields an "effective specific heat" of 1.14, a value somewhat above that of water.

Of course, there is a good probability that energy will not be available at 100°C to vaporize the water. However, the reaction and its operating conditions were both chosen quite arbitrarily. If the atmosphere temperature were 7°C (44°F), water would condense at 1.0 kPa (0.01 atm.) pressure or more. Therefore, the storage charging reaction could take place at a temperature somewhat greater than 390°C (734°F) corresponding to an equilibrium pressure of 1.0 kPa in Figure 5-2. The energy evolved during condensation of the water vapor at 7°C would now be given off to the environment as shown in Figure 5-7 and "stored" there. When energy is required from storage, the water would be vaporized at a temperature slightly below 7°C using the "stored" heat in the atmosphere to give a water vapor pressure below 1.0 kPa. Thus, from the equilibrium curve of Figure 5-2, the reaction of the calcium oxide stored at 390°C and the water vapor would produce heat at a temperature below 390°C and the input and output temperatures could be very similar. Figure 5-8 presents the results of this case graphically, and when compared to Figure 5-6 shows the energy distribution to be very similar. For convenience, all subsequent calculations consider operation of the system at 520°C as an example although different conditions may be required in practice without a major change in the conclusions.

As an independent check on these results, the energy released per weight of total material is shown as a function of temperature in Figure 5-9 for an ammoniated salts system using the coupled reactions 25 and 26.



The thermodynamic data available for the latter two reactions is far less reliable than for the previous pair, and crude estimates must be made to calculate the energy requirements. The first energy storage reaction occurs at 135°C (275°F) for an ammonia pressure of one atmosphere. The second reaction is used to store the ammonia and take place at about 32°C (90°F) at one atmosphere ammonia pressure. Both salts are stored at their reaction temperatures, and the energy available below 135°C is again that associated with the cool down and reaction of ammonia (reaction 26) for storage. This system must be operated in a chemical heat pump mode if the gaseous ammonia is to be stored with the solid CaCl₂ by reaction 26. Although the total possible chemical heat pump coefficient of performance is higher than for calcium oxide/hydroxide, the percent energy delivered at the storage generation temperature is only slightly better than before.

Some additional penalty must be assessed against storage system efficiencies to account for thermal losses of the materials stored at high-temperatures. Considering the final

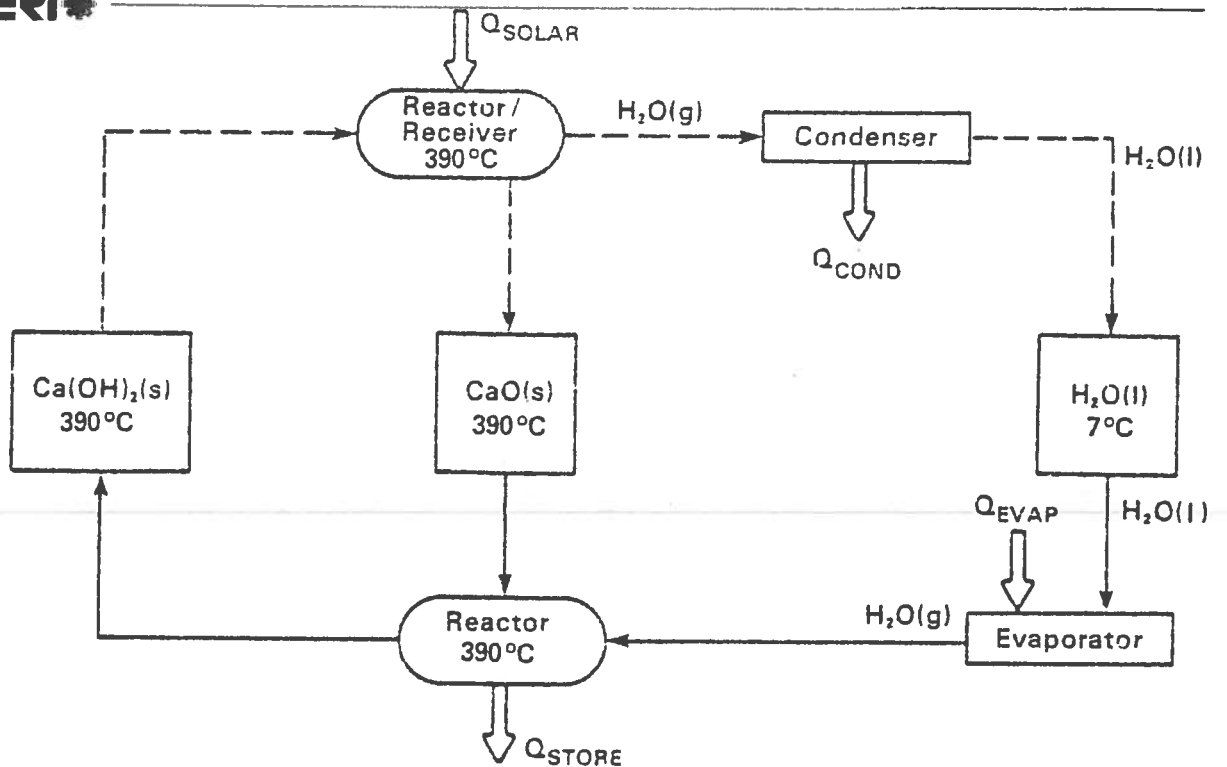

Figure 5-7. THERMAL ENERGY STORAGE SYSTEM BASED ON CALCIUM OXIDE/HYDROXIDE WITH SOLIDS STORED AT 390°C AND WATER CONDENSED, STORED, AND VAPORIZED USING ATMOSPHERIC TEMPERATURES. THE CHARGING CYCLE IS SHOWN BY DASHED LINES AND THE DISCHARGING CYCLE IS SHOWN BY SOLID LINES

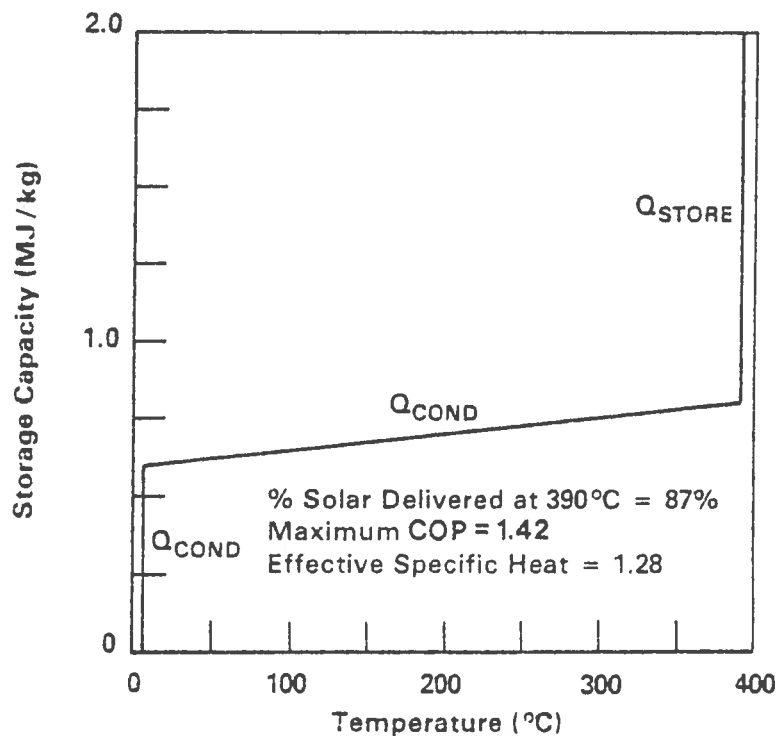

Figure 5-8. ENERGY RELEASED AS A FUNCTION OF TEMPERATURE FOR THE CHEMICAL HEAT PUMP SYSTEM SHOWN IN FIGURE 5-7

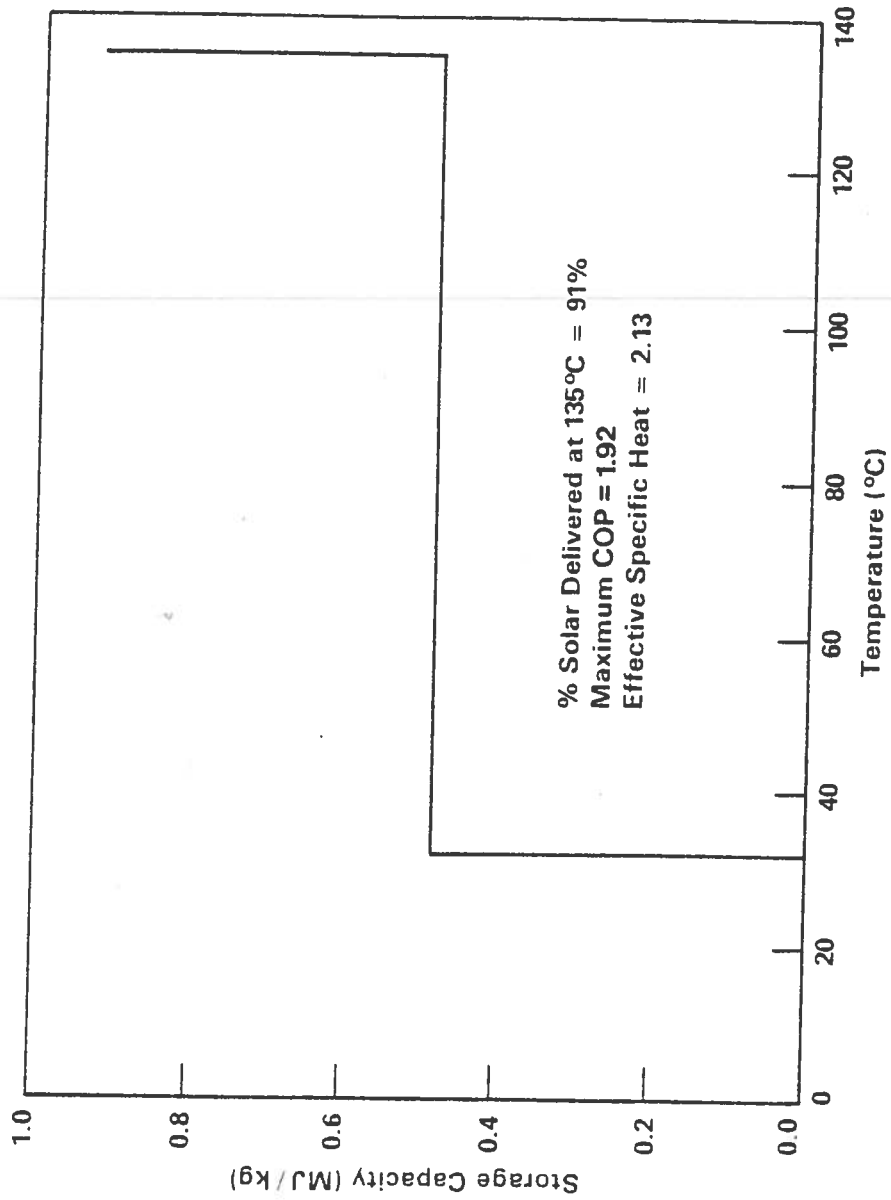

Figure 5-9. ENERGY RELEASED AS A FUNCTION OF TEMPERATURE FOR AN AMMONIATED SALTS CHEMICAL HEAT PUMP SYSTEM WITH STORAGE OF MATERIALS AT REACTION TEMPERATURES

total efficiency, complexities of operation, and temperature drops between the storage and release conditions, chemical reactions with material maintained at the high temperatures appear less desirable for thermal energy storage than latent heat-of-fusion materials. The only advantage offered by the reactions is a generally higher energy storage density at the elevated temperatures. This advantage is slight for many of the reactions. However, if the reactants and products could be stored at temperatures close to ambient, the thermal losses and container corrosion problems in storage would be substantially reduced, and chemical storage would offer substantial advantages.

The simplest way to get the products to ambient conditions is to let them give off their sensible heat either to the load if it can be used at the available temperatures or to the surroundings if it cannot. If calcium hydroxide is stored at 25°C, it can be dehydrated at one atmosphere pressure by heating it up to 520°C. (Figure 5-10.) The calcium oxide and water vapor produced at 520°C are then cooled down to 25°C (or any other low-temperature) for storage. When energy is required from storage, the cool water and calcium oxide react in much the same way as for hydrated lime production, and energy is drawn off at 520°C. The calcium hydroxide is then cooled down from 520°C to 25°C.

Figure 5-11 presents the distribution of released energy with respect to available temperature for the operational scheme just described. The small amount of energy shown at 520°C is that released during the discharge reaction while the larger quantity of energy released at 100°C arises from condensing the water for storage. The sloping lines in the figure represent the energy released in cooling down the calcium oxide and water to 25°C after charging storage as well as the energy available in cooling down the calcium hydroxide after the discharge reaction. As shown in the figure, only 14% of the solar energy added to the system is available at the original input temperature of 520°C. If the energy is useful at all temperatures, then a coefficient of performance equal to one results although the wisdom of using a 520°C collector to generate so much low-temperature energy could be questioned.

As discussed previously, evaporation of the water by waste heat (or ambient heat if all other conditions are altered) increased the temperature of the energy delivered. If this chemical heat pump mode is adopted again to heat the stored water from 25°C to 100°C and vaporize it using waste heat as shown in Figure 5-12, the energy distribution is as shown in Figure 5-13. The chemical heat pump operation makes it possible to deliver 44% of the input solar energy near the 520°C temperature. It is theoretically possible to obtain 30% more energy from the storage system than the energy used to charge it although most of the energy is no more useful in the process than the "waste" heat used to evaporate the water. Figure 5-14 presents similar results to those discussed above for the ammoniated salts system of Equations 25 and 26. Sixty-nine percent of the solar energy used to charge storage is available now during discharge at the higher temperature.

From the preceding results, it is apparent that the sensible heat changes associated with heating and cooling the reactants and products is significant. For home heating or other applications in which energy is useful over a wide spectrum of temperatures, the operational schemes can be adjusted only slightly from the simplistic ones discussed

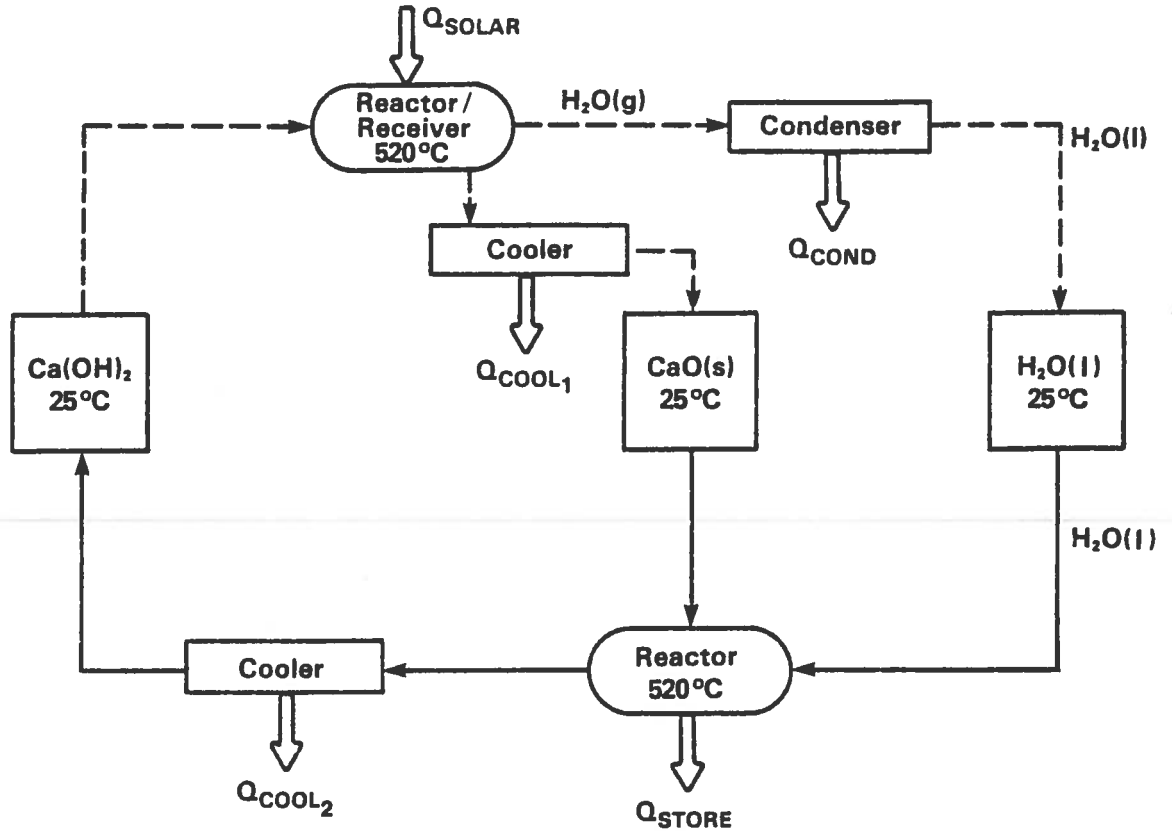

Figure 5-10. THERMAL ENERGY STORAGE SYSTEM BASED ON CALCIUM OXIDE/HYDROXIDE WITH MATERIALS STORED AT 25°C. THE CHARGING CYCLE IS SHOWN BY DASHED LINES AND THE DISCHARGING CYCLE IS SHOWN BY SOLID LINES

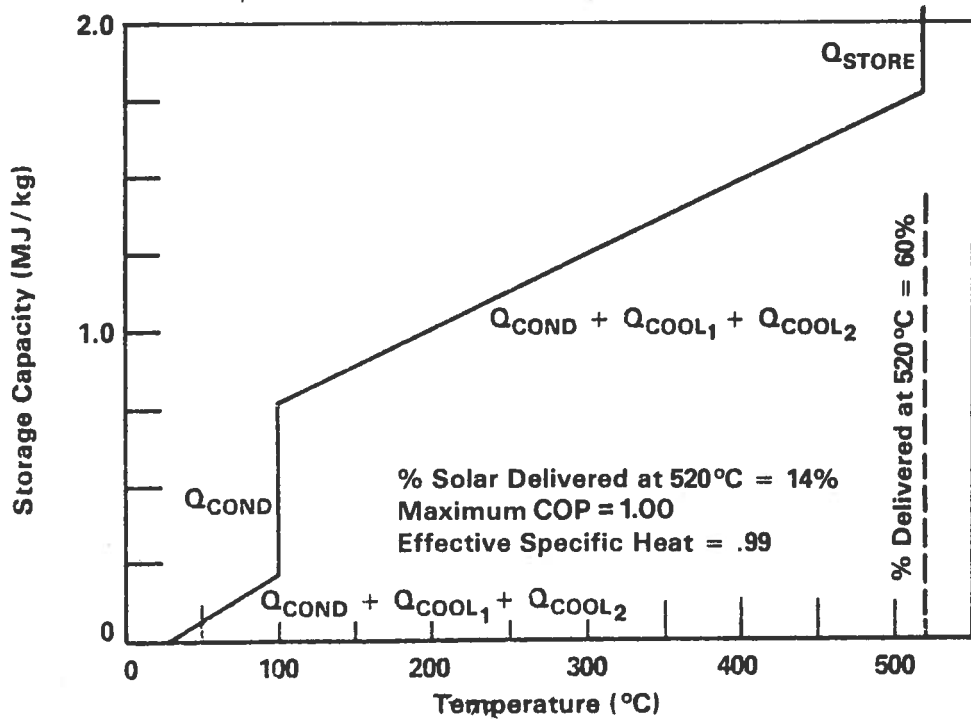

Figure 5-11. ENERGY RELEASED AS A FUNCTION OF TEMPERATURE FOR THE CALCIUM OXIDE/HYDROXIDE SYSTEM IN FIGURE 5-10

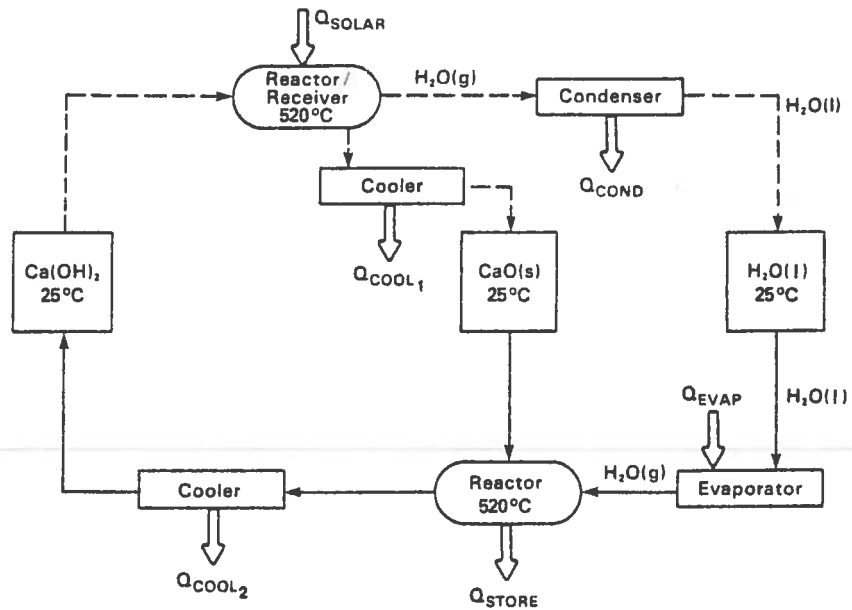

Figure 5-12. THERMAL ENERGY STORAGE SYSTEM BASED ON CALCIUM OXIDE/HYDROXIDE IN CHEMICAL HEAT PUMP MODE AND WITH MATERIALS STORED AT 25°C. THE CHARGING CYCLE IS SHOWN BY DASHED LINES AND THE DISCHARGING CYCLE IS SHOWN BY SOLID LINES

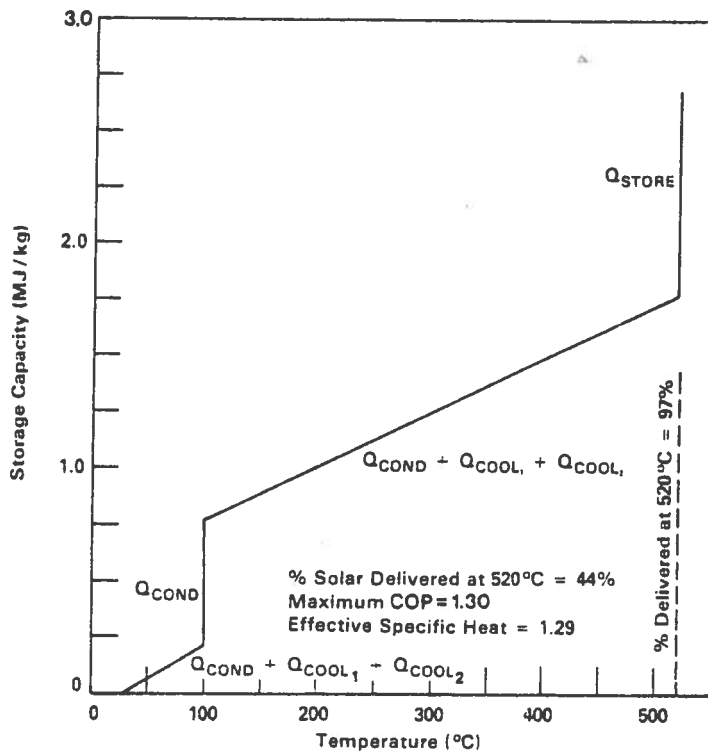

Figure 5-13. ENERGY RELEASED AS A FUNCTION OF TEMPERATURE FOR THE CHEMICAL HEAT PUMP MODE OF FIGURE 5-12

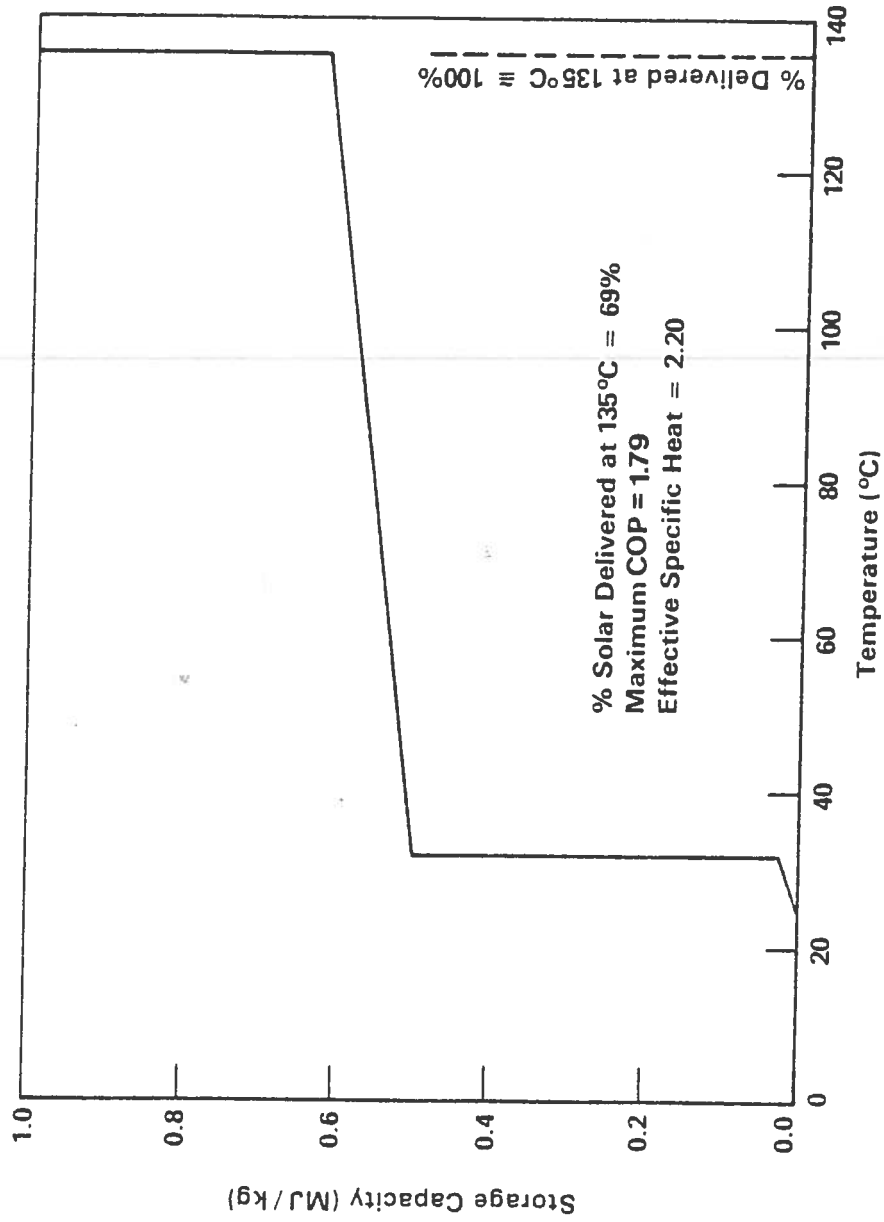

Figure 5-14. ENERGY RELEASED AS A FUNCTION OF TEMPERATURE FOR AMMONIATED SALTS IN THE CHEMICAL HEAT PUMP MODE WITH ALL MATERIALS STORED AT 25°C

above to take advantage of unique heat pumping capabilities, and more energy can be obtained in principle from the system than was applied by solar. In these cases, the sensible heat is used more effectively. It is possible that the energy distribution curves such as in Figure 5-13 may match the load requirements for high-temperature processes. However, the operational schemes described are not generally satisfactory for applications where significant value is placed on high-temperature heat but little if any value is placed on low-temperature heat.

Dramatic improvements in high-temperature energy delivery capabilities are possible if the energy storage and release reactions are carried out in continuous reactors with heat exchange. For example, to charge storage, the calcium hydroxide at 25°C could be first passed through a countercurrent heat exchanger and then into a reactor where solar energy would drive the reaction at 520°C. The calcium oxide and water vapor would be separated at the reaction temperature to prevent subsequent back reaction, and then the two products would flow back through the heat exchanger to give up their sensible heat to the incoming calcium hydroxide. More sensible heat is available for heat exchange in the products than required by the reactants, and assuming the reactants could be heated to close to 520°C in the heat exchanger, about 1.46 MJ of solar energy is needed per kg of calcium hydroxide to charge storage.

Two possibilities can be devised to use the energy from storage. First, liquid water and calcium oxide at 25°C are passed through separate passages in a countercurrent heat exchanger and are mixed in a continuous reactor to produce a temperature of 520°C. Energy is taken from the reactor at 520°C by the load, and the calcium hydroxide produced flows back through the countercurrent heat exchanger to give up its sensible heat to the incoming reactants. More energy is now needed to heat the reactant to 520°C than is available in the products, and the energy available from the reactor is 0.879 MJ per kg of Ca(OH)_2 . Thus, just over 60% of the solar energy required to charge storage is available at 520°C assuming effective heat exchange is possible. Although this is not completely satisfactory, it is a dramatic improvement over the 14% level observed in Figure 5-11 for the same concept but without heat exchange. The energy delivered at 520°C in the heat exchange system is shown graphically by the dashed line in Figure 5-11. The energy "wasted" at other temperatures is not shown since the data available to perform the more detailed analysis required to determine the profile is sketchy.

The second route employed to release the stored energy combines the chemical heat pump mode with the heat exchange system to make up for the "wasted" heat. Water is heated up from 25°C to 100°C and vaporized using heat available above 100°C. The vaporized water and the cool calcium oxide then pass through separate passages in a countercurrent heat exchanger. These materials are mixed in a reactor where they give up heat at 520°C for the load. The calcium hydroxide formed passes back through the counterflow heat exchanger to give up its heat to the incoming reactants. Somewhat more sensible heat is available in cooling down the calcium hydroxide than is required to heat up the oxide and water vapor; and 1.410 MJ of energy is released to the load per kg of calcium hydroxide produced assuming complete heat exchange is possible. Thus, as shown by the dashed line in Figure 5-13, about 97% of the solar energy needed to charge

storage is available at the input temperature (520°C). The dashed vertical line in Figure 5-14 shows the result of combined heat exchange and heat pumping for ammoniated salts. An essentially 100% efficiency is predicted.

The analysis used here is cursory in nature and neglects some of the practical considerations which must be addressed for real systems. For instance, some drop will be required in the energy release temperatures if the heat for vaporizing water during discharging of storage is pumped from the heat sink used during charging. The exact amount of this shift depends on the reaction kinetics and reactor design tradeoffs. The temperatures of the heat source and sink for heat pumping depend on the application and location, and the system operating temperature must shift to fit the equilibrium requirements for these temperatures. Furthermore, reactions other than calcium oxide/hydroxide and ammoniated salts are available, and the operating temperatures will be altered for different systems. To be complete, studies must be done of an integrated solar/storage system. However, in the final analysis, the basic conclusion should still remain: heat exchange and chemical heat pumping are necessary for chemical storage at ambient temperatures if a reasonable fraction of the solar energy used to charge storage is to be delivered at a temperature close to that of the collector. Heat exchange decreases the amount of sensible heat losses while chemical heat pumping counteracts the losses that are apparently unavoidable if materials are to be stored at ambient conditions. For gas-solid reactions, substantial research and development are required to economically and efficiently provide these capabilities.